



TENDER FOR

**RATE CONTRACT AND EMPANELMENT FOR G. I.
PIPE, LAYING OF MDPE PIPELINE NETWORK FOR
DOMESTIC PNG CONNECTIVITY AT KANPUR,
UNNAO,
BAREILLY & JHANSI GA**

THROUGH E-TENDERING MODE

TENDER NO : CUGL/C&P/TEN2324/67

**TECHNICAL VOLUME
(II of II Part IIC of II)**

**CENTRAL U.P. GAS LIMITED
Kanpur | India**

INDEX

Sr No	DESCRIPTION
1.	SCOPE OF WORK
2.	STANDARD SPECIFICATION
3.	QUALITY ASSURANCE PLAN
4.	VENDOR LIST
5.	STANDARD DRAWING

PROJECT NUMBER: 1036



SCOPE OF WORK	CLIENT JOB NO	1 0 3 6			
		TOTAL SHEETS			
DOCUMENT NO	C211036	CGD	PL	SOW	

**CENTRAL UP GAS
Limited**

**RATE CONTRACT AND EMPANELMENT FOR LAYING
OF MDPE PIPELINE NETWORK FOR DOMESTIC PNG
CONNECTIVITY AT KANPUR, UNNAO, BAREILLY &
JHANSI GA**

SCOPE OF WORK

--	--	--	--	--

Format: VPC-EN-005-03

©



TABLE OF CONTENTS

1.0	INTRODUCTION.....	3
2.0	PURPOSE.....	3
3.0	DEFINITIONS	3
4.0	DOCUMENT PRECEDENCE	4
5.0	SCOPE OF WORK	4
6.0	CONDITIONS FOR ISSUE OF MATERIALS	10
7.0	RECONCILIATION OF OWNER SUPPLIED MATERIALS.....	10



1.0 INTRODUCTION

M/s Central U.P. Gas Limited (CUGL) a Joint Venture of India's two Maharatana Companies, GAIL (India) Limited and Bharat Petroleum Corporation Limited incorporated on 25th February 2005. CUGL is authorized by the Petroleum and Natural Gas Regulatory Board (PNGRB) to operate in the Geographical Areas (GAs) of Kanpur (including some part of Unnao), Bareilly and Jhansi.

Central UP Gas Limited, invites tenders under sealed covers from bona fide and experienced Contractors of financial standing and reputation for the following job:

RATE CONTRACT AND EMPANELMENT FOR LAYING OF PE NETWORK AT KANPUR, UNNAO, BAREILLY & JHANSI GA.

Central UP Gas Limited (CUGL) (hereinafter referred as Owner), is supplying Piped Natural Gas (PNG) to domestic, commercial, and industrial consumers and compressed natural gas (CNG) to automobiles in above mentioned GAs through its CGD and CNG networks. CUGL intends to develop its CGD and CNG network in above mentioned GA.

2.0 PURPOSE

This document is for the scope of empaneling the contractor on rate contract for Laying of PE Network AT KANPUR, UNNAO, and BAREILLY & JHANSI GA.

3.0 DEFINITIONS

Where used in this document, the following terms shall have the meanings indicated below, unless clearly indicated by the context to this order

PROJECT	LAYING OF PE PIPELINE NETWORK AT KANPUR, UNNAO, BAREILLY & JHANSI GA
OWNER	Central UP Gas Limited (CUGL)
MANUFACTURER	The party, which manufactures and supplies equipment and



RATE CONTRACT AND EMPANELMENT FOR LAYING OF PE PIPELINE NETWORK AT KANPUR, UNNAO, BAREILLY & JHANSI GA

	services to the OWNER or to Contractor
SOW	SCOPE OF WORK

4.0 DOCUMENT PRECEDENCE

It shall be the responsibility of the Contractor/ BIDDER to inform the OWNER of any errors, ambiguities, inconsistencies, discrepancies, or conflict of information that may be found to exist in any document, specification or drawing provided in the tender by the OWNER.

In case of conflict, the order of precedence shall be as follows:

- a. Scope of Work(SOW)
- b. Schedule of Rates(SOR)
- c. Data Sheets & QAP
- d. Standard Specifications
- e. Codes and Standards

As a general rule in the event of any discrepancy between technical matter and local laws/ regulations (and documents above listed) the most stringent shall be applied.

CONTRACTOR/ BIDDER shall notify OWNER of any apparent conflicts between SOW, Technical specifications, related datasheets, any code and standards and any other specifications noted herein. (Resolution and/ or interpretation precedence shall be obtained from OWNER in writing before proceeding with the design/ manufacturer or completion of services.)

5.0 SCOPE OF WORK

The main scope of work comprises laying, testing, and commissioning of underground Polyethylene (PE) main and service pipelines network of sizes ranging from 20mm up to 125mm Dia. Up to Transition Fitting (TF) along with a GI riser of 1.5 m height, in all the households allocated by CUGL for PNG Connections to Domestic consumers for City Gas Distribution project including fabrication and installation of markers, foundation works, installation of Valve chambers, Installation of Service Regulator (SR), collection of data for GIS mapping and imposing the same on Q-GIS/Google Earth and Restoration as per SOR. The scope also covers all the activities associated with the supply of materials (except free issue items).

Owner’s scope of supply (Free Issue Item).

- PE Pipes of sizes from 20mm up to 125mm Dia.
- SR without cover box.
- Isolation Valve

CONTRACTOR'S SCOPE OF WORK

Supplied by the contractor

- PE valves & fittings of sizes 125mm to 20mm
- Transition fittings
- Warning mat.





RATE CONTRACT AND EMPANELMENT FOR LAYING OF PE PIPELINE NETWORK AT KANPUR, UNNAO, BAREILLY & JHANSI GA

- HDPE pipes and its associated accessories.
- Powder coated GI & Fitting Etc.
- All PPE materials required for safe execution of projects.
- As other materials required for smooth execution of project over and above as mentioned.

All above supply quantity as per relevant SOR item and shall be procured from owners approved vendors only after approval from CUGL/PMC & as per instruction of Engineer-in-charge (EIC).

Generally, the following shall constitute the contractor's scope of work but not limited to:

1. Contractor to provide Work Implementation & Execution plan along with a schedule for execution and work implementation as per QA/QC plans to be issued by Owner/Owner's representative. Contractor has to submit the Construction/ Execution procedures before commencement of work to Owner/ Owner's representative for approval.
2. Prior to start of construction activity, contractor shall carry out the route survey and prepare the approval for construction (APC) drawings marked for proposed gas pipeline laying and submit to OWNER/ PMC for approval.
3. Co-ordination/ Liaison/ Permissions/ Obtaining the approval from respective land- owning agencies such as Municipal Corporation, CPWD, ADA/ LDA, Nagar Nigam, PWD- NH, NHAI, Indian Railway, Forest & Environment Department, Irrigation department and other land owing agencies for road cutting for laying of the pipelines, Liaison with the concerned authorities during execution of the job, obtaining NOC from concerned authorities once the work is completed. Getting back/ refund of bank guarantee/security deposits made to the agencies for laying of the pipelines.
4. Obtaining clearances and coordination with concerned RWA of the allotted area for internal network laying and obtaining NOC from RWA after completion of work.
5. Transportation of Free Issue material from OWNER stores to contractor stores and proper storing, stacking, providing security, insurance cover during transportation and storage, laying, commissioning, and handing over pipelines to owner.
6. Obtaining the approval for optimum route and ROU from the concerned authority and CUGL/PMC.
7. Intimation to the parallel utilities (Electrical, Communication, Water etc.) owners and making trial pits to determine the underground utilities/services such as existing pipelines, cables (electrical/ communication), conduits, U/G drainage, Sewers, tunnels, subways foundations etc. for deciding optimum feasible route and depths for laying the pipelines based on the route plans indicated by owner.
8. Carrying out Ground Penetrating Radar (GPR) survey from recognized agencies to determine the underground utilities/ services such as existing pipelines, cables (electrical/communication), conduits, U/G drainage, Sewers, tunnels, subways foundations etc. for deciding optimum feasible route and depths for laying the pipelines based on the route plans.
9. Contractor must arrange road cutter machine for all areas where road cut need to be done.



**RATE CONTRACT AND EMPANELMENT FOR LAYING OF PE PIPELINE NETWORK
AT KANPUR, UNNAO, BAREILLY & JHANSI GA**

10. Wherever required the grass/ turfing, pavement, linings, drains, roads and other such 'pucca' area shall be locally removed to facilitate trenching and pipe laying works. The same is to be reinstated as original.
11. Installation of safety/warning signs and barricading of the entire route to be trenched. Pits to be similarly barricaded along with warning signs and caution boards. Photograph of each trench with geostamp and timestamp required after laying, placing warning mat and restoration respectively.
12. To make trenches with stable slopes but restricting minimum disturbance to above ground/underground services/installation as per specifications and approved route plans keeping the trenches free from water and soil till placement of pipes.
13. Uncoiling/stringing the PE pipes of required sizes (i.e. 125mm, 63mm, 32mm & 20 mm) pipes into trenches as per approved procedure.
14. Supply and Installation of PE pipe Rest material and fittings like Elbow, Tees, Reducers, Couplers, bends, tapping saddles, Transition fittings, End cap and Half Concrete Sleeves HDPE pipe etc. including construction of supports, Valves pits, Inspection chambers etc. as per specification, drawing & satisfaction of the Engineer in charge (EIC).
15. Joining the pipe ends with fittings of valves by approved automated electro-fusion techniques only as per tender specification.
 - Electrofusion (EF) machine should be one having bar code reader available in market.
 - EF operator to be deployed for EF welding must be certified from approved vendors of EF fittings manufacturer like GF/ Kimplas/ Section IX of ASME BPV.
 - Contractor obtain latest welder I-Card by getting training from approved agencies with practical knowledge of EF welding on highest dia. on which work is intended.
16. Laying pipelines by any methodology including trench less technology methods with or without casing pipes (HDPE pipes) as per specifications and as directed by CUGL/PMC.

Photos and videos with accurate geo reference and time stamp during lowering need to be captured by contractor and GPS Coordinates/ points to be mentioned in lowering report for each EF joint. Site Photographs for before and after scenarios showing trenching, its barricades and restoration to be captured with geo co-ordinates and time stamp.
17. Contractor must take geostamped and time stamped photo of each EF welded joint and submit for Project in charge records on daily basis. Only hydraulic squeezers are allowed, and re-rounding tools are required.
18. Installation of pipes (by open cut/ Moling/ HDD) assembly, including supply of all materials (excluding free issue material if any) viz. as per the drawings/ specifications enclosed with bid package. HDD methodology and its profile submission prior to execution of HDD should be in contractor scope. Also, RCC route markers shall be installed at minimum spacing of 50 m and should be integral part of PE laying.
19. Moling should be done with Teflon coated crowbar extension only and with proper ventilation in Moling pit. Electrical utility to be identified prior to attempting manual boring.
20. All tools & equipment's shall be provided by the contractors for PE laying and GI Installation. HDD profile and Utility coordination report to be submitted before HDD approval to CUGL/PMC. Any HDD performed beyond the intended /approved length will be paid as per Open trench SOR.



**RATE CONTRACT AND EMPANELMENT FOR LAYING OF PE PIPELINE NETWORK
AT KANPUR, UNNAO, BAREILLY & JHANSI GA**

21. Contractor should submit following set of daily reports (Planning, Manpower, Material Inventory, DPR) and monthly reports (QC, material reconciliation, DPR, Capitalization etc.) Contractor should submit daily site wise activity geostamped and timestamped photos to CUGL/PMC. Contractor should collect GIS data and impose the same on Q-GIS/Google Earth and submit soft copy to CUGL.
22. Contractor must also have to arrange his own equipment like water tanker for Water showering on construction site (trench valves pit areas).
23. Contractor to depute Storekeeper, HSE person and draftsmen for allotted work. One supervisor is required for each working site area. Fabrication, supply and inspection of approved quality GI sleeve, HDPE duct and half concrete sleeves and other material, fittings to be supplied by the contractors as per the provisions of tender.
24. Back filling and compaction by jumping jack compactor wherever required, using approved 'good' soil or using excavated earth or borrow earth as per requirement and specifications and replacement of the tiles, slabs removed during the excavation. Cleaning all unserviceable materials, debris, excess earth trenches etc. to designated disposal area.
25. The contractor shall be responsible to arrange the supply of approved coarse sand (size 0.6 - 2 mm as per IS 383) free from any impurities like clay, mica, and soft flaky pieces, as per the instructions of CUGL/PMC/TPIA.
26. Sand / soft soil padding around pipe wherever required in areas where trenching has been done in hard soil area / rocky area including supply of sand/ soft soil. The thickness of sand/ soft soil padding at the top of coated pipe shall be minimum 150 mm and bottom of coated pipe shall be minimum 150 mm or as per standard drawing.
27. Carrying out pneumatic testing and purging as per specifications and approved procedures, providing all tools & tackles, instruments, manpower and other related accessories for carrying out the testing of pipes.
28. Supply, fabrication & installation of RCC route marker, Pole marker with foundations, Plate markers, valve chamber etc. as per the directions of CUGL/PMC/TPIA.
29. Nitrogen Purging should be done to point till Oxygen percentage is less than 2%. Contractor must arrange Purity certificate of Nitrogen used for purging. It is compulsory to use Nitrogen cylinder trolley while using Nitrogen for purging/ testing. It must be necessary to qualify welder/ manpower for Procedure Qualification Record for performing testing by pressure testing the PE pipe coil. Nitrogen purging (including supply), commissioning and gas charging in the tested PE line shall be done as per the approved procedure.
30. Restoration of existing ground features such as grass/ turfing, paving, roads, drains, concrete, floral beds, fencing, tiles, marbles, flooring masonry etc. to original condition and to match with adjoining conditions, functionally and aesthetically up to the entire satisfaction of Owner / Owner's representative /any other third party agency designated by owner and local authorities, failing which, it will be done at the risk and cost of the contractor. Obtaining No Objection Certificates for the restoration work done from the concerned authorities.

Restoration should be done to satisfaction of CUGL/PMC/TPIA and Authority. Contractor must arrange joint site visit report for restoration and submit restoration report.
31. Returning surplus material to Owner stores after obtaining clearance from TPIA/Consultant/ Owner, reconciliation of free issue material/ consumables.



**RATE CONTRACT AND EMPANELMENT FOR LAYING OF PE PIPELINE NETWORK
AT KANPUR, UNNAO, BAREILLY & JHANSI GA**

32. Handing over the completed works to owner along with detailed as built drawing showing pipeline route, fittings provided in the pipelines, for their operation purposes. Handing over 3 sets of completed as Built drawings which are GIS compliant. Also required handing over of Non-LMC above ground drawings (including Riser drawings) in editable Auto-Cad as well as PDF format.
33. Maintaining the completed pipelines/installation for any failure and defect arising due to poor workmanship during defect liability period.
34. Preparation and submission of all documents like Pit Wise as graph, As-built drawings, details of crossings, utility graphs, measurement sheet, PE cards for service line and deviation statements on completion/commissioning of work by way of drawing, sketches and tables in soft & hard copy.
35. Providing adequate manpower, tools, tackles, equipment for achieving the target of pipeline laying, data logging for pipeline, valves and fittings inventory status, attending complaints, day to day interaction with customers and residents so that work can be executed within defined time period.
36. Contractor should identify the name of local authority maintaining the road or drainage/canal & provide hard copy of final survey drawing after incorporating all comments from owner's representative
 - Survey drawing should mention suggested pipeline route in a separate layer for EIC approval before commencing laying.
 - CUGL/PMC to approve line sizing after network hydraulics check /confirmation in a format and linked to annual budget.
37. Following activities are also in contractor's scope:
 - Receive Customer's complaints logged during PE Laying.
 - Attend and Carry out joint technical feasibility survey for requests and resolve the complaint.
 - Maintain and update the complaint status.
38. Repair and Maintenance of PE pipeline as excavation, leakage arrest, jointing and restoration of any size including supply and installation of all fittings required in case of third-party damage after commissioning. PE Pipe required shall be issued by Owner as free issue material.
39. All skilled personnel like jointers, conversion technicians will be approved and certified by EIC based on the test conducted by approved trainers.
40. Contractor shall visit and survey all areas where PE laying is planned or in progress.
41. Any other activities not mentioned/ covered explicitly above, but otherwise required for satisfactory completion/ operation/ safety/ statutory/ maintenance of the works shall also be covered under the Scope of work and has to be completed by the Contractor within specified schedule at no extra cost to Owner.
42. Installation of Service Regulator as per standard drawing
43. Supply and installation of GI pipe up to 1.5m from Transition Fitting (TF)

Part I: PE Service Line

1. Obtaining the approval for optimum route and permission for work from society management, RWA, individual residents and any other concerned authority, if required, for completion of the work.
2. Selection of route with the CUGL/PMC/TPIA and marking the same on walls/floors from PE network, transition fittings to riser of 1.5m.
3. Uncoiling/stringing the PE pipes of required sizes (20mm, 32mm & 63mm) pipes into trenches as per approved procedure.
4. Joining the pipe ends with fittings of valves by approved automated electro-fusion techniques only as per tender specification.
5. Supply and Installation of PE pipe fittings like Elbow, Tees, Reducers, Couplers, tapping saddles, Transition fittings, Valves and Sleeves etc. including construction of supports, Valves pits, Inspection chambers etc. as per specification, drawing & satisfaction of the Engineer In charge (EIC).
6. Laying pipelines by any methodology including open cut, trench less technology methods like Moling, HDD, etc.
7. Fabrication, supply and inspection of approved quality GI sleeve, HDPE duct and half concrete sleeves and other material, fittings to be supplied by the contractors as per the provisions of tender.
8. Back filling and compaction by jumping jack compactor wherever required, using approved 'good' soil or using excavated earth or borrow earth as per requirement and specifications and replacement of the tiles, slabs removed during the excavation. Cleaning all unserviceable materials, debris, excess earth trenches etc. to designated disposal area.
9. Carrying out pneumatic testing and purging as per specifications and approved procedures, providing all tools & tackles, instruments, manpower and other related accessories for carrying out the testing of pipes.
10. Restoration of existing ground features such as grass/turfing, paving, roads, drains, concrete, floral beds, fencing, tiles, marbles, flooring masonry etc. to original condition and to match with adjoining conditions, functionally and aesthetically up to the entire satisfaction of Owner / Owner's representative /any other third party agency designated by owner and local authorities, failing which, it will be done at the risk and cost of the contractor. Obtaining No Objection Certificates for the restoration work done from the concerned authorities
11. Handing over the completed works to owner along with detailed as built drawing showing pipeline route, fittings provided in the pipelines, for their operation purposes.
12. Installation of powder coated GI pipes of ½" dia. from transition fittings to 1.5m height appliances including NPT threading of GI pipes, supply proper seal outs for threads to join fittings such as elbows, tees, connectors, regulators, meters, appliance & isolation valve etc., as per laid procedures and specification including clamping and sealing etc. The scratched powder coated GI pipe and fittings shall be painted after the testing of the GI installation.
13. Cleaning, flushing, pneumatic testing of GI pipe and fittings etc., as per specification and hand over the same to Owner/customer to the entire satisfaction of EIC.
14. Pneumatic testing of Riser at 2 bar (g) for 2 hours shall be done.



RATE CONTRACT AND EMPANELMENT FOR LAYING OF PE PIPELINE NETWORK AT KANPUR, UNNAO, BAREILLY & JHANSI GA

15. All the painting work must be done after completion of testing activity only. All GI fittings must be Powder coated.
16. Any other activities not mentioned/covered explicitly above, but otherwise required for satisfactory completion/operation/ safety/ statutory/ maintenance of the works shall also be covered under the Scope of work and has to be completed by the Contractor within specified schedule at no extra cost to Owner.

6.0 CONDITIONS FOR ISSUE OF MATERIALS

Whenever any material is issued by Owner, following conditions for issue of material in addition to other conditions specified in the contract shall be applicable.

1. Necessary indents will have to be raised by the Contractor as per procedure laid down by the Engineer-in-charge from time to time, when he requires the above material for incorporation in permanent works.
2. Materials will be issued only for permanent works and not for temporary works, enabling works etc. unless specifically approved by the Engineer-in-charge and the same shall not be taken into account for the purpose of materials reconciliation.
3. The contractor shall bear all other cost including lifting, carting from issue points to work site/ contractor's store, custody and handling etc. and return of surplus/ serviceable scrap materials to Owner's storage points to be designated by the Engineer-in-charge etc. No separate payment for such expenditure will be made.
4. No material shall be allowed to be taken outside the store without a gate pass.
5. The contractor shall be responsible for proper storage, preservation and watch & ward of the materials.

7.0 RECONCILIATION OF OWNER SUPPLIED MATERIALS

- 7.1** The Contractor is responsible for reconciliation of material used for job completed in a month. This record will be used for the reconciliation of material at the end of the contract.
- 7.2** The full replacement or repair costs of all damages items will be recharged to the contractor.
- 7.3** It is mandatory that the contractor is required to undertake and submit inventory details of free issue and purchased materials on monthly basis to Owner/ Owner's representative as per the approved format of the owner. The inventory details shall be in correlation with the Daily progress chart and material reconciliation sheet. Material reconciliation statement of all free issue materials shall be carried out on monthly basis & reconciliation statement shall be submitted to Owner along with invoices.
- 7.4** After the final reconciliation is carried out, the variances in materials issued against materials used and returned, will be assessed. All unused, scrap materials and salvageable materials shall be the property of the Owner and shall be returned by the Contractor category-wise at his cost to the Owner's designated store. In case the Contractor fails to do so or exceeds the limits of allowances specified below for scrap/ serviceable materials, then recovery for such quantities not returned as well as returned in excess of permitted limit by the Contractor will be done at the penal rate i.e. 200% (Double the landed cost) at the time of final bill/ closing of contract by Engineer-in-charge shall be effected from the Contractor's bill (s) or from any other dues of the Contractor to the Owner. Contractor shall be responsible for the adjustment and measurement of the surplus materials to be returned to the store.



**RATE CONTRACT AND EMPANELMENT FOR LAYING OF PE PIPELINE NETWORK
AT KANPUR, UNNAO, BAREILLY & JHANSI GA**

Contractor shall also be responsible for suitable segregation of returned materials into separate stacks of serviceable and scrap materials as per instruction of Owner. Wherever certain material is covered under Contractor's scope of supply whether part or in full for any item of work covered under SOR, no allowance towards wastage/ scrap etc. shall be accounted for during execution stage.

ITEM	UNACCOUNTABLE	SCRAP
PE pipes	2%	2% (less than 2.0 mtrs)
Service Regulator	0%	0%

7.5 Material consumption will be recorded. Material issued from the OWNER stores shall be consumed, recorded and returned using the same OWNER item code.

7.6 Any payments due to the Contractor may be withheld to cover these charges.

7.7 All waste materials, part lengths of pipe and other partly used items are the property of OWNER and must be returned to the stores with the appropriate documentation so that they can be considered as part of the material reconciliation.

Unaccountable wastage/ scrap shall be at actual as per site assessment subject to maximum as stated above.

The percentage allowance shall be accounted on the basis of final measurement book.

1. Contractor shall be responsible for the adjustment/ weightment/ measurement of the surplus materials & to be returned to the store. Contractor shall also be responsible for suitable segregation of returned materials into separate stacks of serviceable and scrap materials.
2. Scratched PE pipes acceptable allowance should not more than 10 percent of the O.D.
3. Wherever certain material is covered under Contractor's scope of supply whether part or in full for any item of work covered under SOR, no allowance towards wastage / scrap etc. shall be accounted for during execution stage.

CONTENTS

1.0	GENERAL INFORMATION.....	3
2.0	DEFINITIONS	3
3.0	SCOPE OF WORK	3
4.0	MATERIAL, MANPOWER, EQUIPMENT AND MACHINERY	6
5.0	PROGRESS OF WORK.....	8
6.0	APPROVALS & PERMISSIONS FOR PIPELINE LAYING	8
7.0	REFERENCE SPECIFICATION, CODES AND STANDARD	9
8.0	QUALITY OF WORK	9
9.0	SAFETY.....	9
10.0	ROUTE SURVEY	10
11.0	ORGANISATION STRUCTURE	10
12.0	STRUCTURES, SERVICES AND OTHER PROPERTY.....	11
13.0	TRENCHING	12
14.0	LAYING	15
15.0	JOINTING OF POLYETHYLENE PIPE	17
16.0	BACKFILLING	18
17.0	MOLING.....	20
18.0	HORIZONTAL DIRECTIONAL DRILLING (HDD)	20
19.0	CASING PIPE	21
20.0	RESTORATION	21
21.0	TESTING.....	22
22.0	PURGING.....	22
23.0	VALVE PITS	23
24.0	CONSTRUCTION OF TRENCHES AND OTHER SCOPE OF WORK IN BUILDER SEGMENT	24
25.0	ROUTE MARKERS	24
26.0	GUIDELINES:	25
27.0	ASSISTANCE IN COMMISSIONING.....	25
28.0	STANDARD OF WORK.....	25
29.0	RECORDING (AS-BUILT DRAWINGS)	25
30.0	CIVIL WORKS	27
32.0	TESTING OF CONSTRUCTION MATERIALS	35
33.0	INSPECTION BY THIRD PARTY INSPECTION (TPI) AGENCIES NOMINATED BY LAND OWNING AGENCIES	36

1.0 GENERAL INFORMATION

Owner is executing project for development of City Gas Distribution in Geographical Area of Kanpur, Unnao Bareilly and Jhansi. OWNER plans to lay an underground PE network and associated works in these GA's.

The objective is to supply Natural Gas to Domestic customers. OWNER is seeking Contractors to assist in meeting the above objective.

The main scope of this specification comprises of Laying of underground Polyethylene (PE) main and service pipelines network. The scope covers all the activities associated with the supply of materials (except free issue material), laying, testing and commissioning of PE main and service pipelines in new Gas charged areas of sizes ranging from 20 mm upto 125mm OD, which includes PE/ GI transition fitting above ground level.

This technical specification defines the basic guidelines to develop an acceptable design and suitable construction methodology for carrying out different activities listed out in the schedule of rates of this tender.

Compliance with these specifications and/ or approval of any of the Contractor's documents shall in no case relieve the Contractor of his contractual obligations.

2.0 DEFINITIONS

OWNER	CENTRAL UP GAS LIMITED (CUGL)
SS	STANDARD SPECIFICATION
TPIA	THIRD PARTY INSPECTION AGENCY
EIC	ENGINEER- IN – CHARGE

3.0 SCOPE OF WORK

Generally, the following shall constitute the contractor's scope of work but not limited to:

- 3.1** Plan and prepare a schedule for execution and work implementation as per QA/QC plans to be issued by Owner/Owner's representative. Contractor has to submit the Construction/Execution procedures before commencement of work to Owner/Owner's representative for approval.
 - 3.2** Prior to start of construction activity, contractor shall carry out the route survey and prepare the approval for construction (AFC) drawings marked for proposed gas pipeline laying and submit to CUGL/PMC for approval.
 - 3.3** Co-ordination /Liaison / permissions/ Obtaining the approval from respective land-owning agencies such as Municipal Corporation, CPWD, ADA/LDA, Nagar Nigam, PWD-NH, NHAI, Indian Railway, Forest & Environment Department, Irrigation department and other land owing agencies for road cutting for laying of the pipelines, Liaison with the concerned authorities during execution of the job, obtaining NOC from concerned authorities once the work is completed. Getting back/refund of bank guarantee / security deposits made to the agencies for laying of the pipelines.
 - 3.4** Obtaining clearances and coordination with concerned RWA of the allotted area
-

for internal network laying and obtaining NOC from RWA after completion of work.

- 3.5** Transportation of Free Issue Material from CUGL's stores to contractor stores, proper storing, and stacking, providing security, transit insurance cover during storage, laying, commissioning and handling over pipelines to owner.
 - 3.6** Obtaining the approval for optimum route and ROU from the concerned authority.
 - 3.7** Intimation to the parallel utilities (Electrical/Communication/Water) owners and making trial pits to determine the underground utilities/services such as existing pipelines, cables (electrical/communication), conduits, U/G drainage, Sewers, tunnels, subways foundations etc. for deciding optimum feasible route and depths for laying the pipelines based on the route plans indicated by owner.
 - 3.8** Wherever required the grass/turfing, pavement, linings, drains, roads and other such 'pucca' area shall be locally removed to facilitate trenching and pipe laying works. The same is to be reinstated as original.
 - 3.9** Installation of safety/warning signs and barricading of the entire route to be trenched. Pits to be similarly barricaded along with warning signs and caution boards.
 - 3.10** To make trenches with stable slopes but restricting minimum disturbance to above ground/underground services/installation as per specifications and approved route plans keeping the trenches free from water and soil till placement of pipes.
 - 3.11** Uncoiling/stringing the MDPE pipes of required sizes (i.e. 125, 63, 32 & 20 mm) pipes into trenches as per approved procedure.
 - 3.12** Joining the pipe ends with fittings of valves by approved automated electro-fusion techniques only as per tender specification.
 - 3.13** Installation of pipe fittings like elbow, tees, reducers, couplers, tapping saddles, transition fittings, valves etc., including construction of supports, valves pits, inspection chambers etc. as per specification & satisfaction of the EIC.
 - 3.14** Laying pipelines by any methodology including trenchless technology methods with or without casing pipes (HDPE pipes) as per specifications and as directed by EIC.
 - 3.15** Fabrication, supply and inspection of approved quality GI sleeve and half concrete sleeves and other materials, fittings to be supplied by the contractors as per the provisions of tender.
 - 3.16** Back filling and compaction by jumping jack compactor wherever required, using approved 'good' soil or using excavated earth or borrow earth as per requirement and specifications and replacement of the tiles, slabs removed during the excavation. Cleaning all unserviceable materials, debris, excess earth trenches etc. to designated disposal area.
 - 3.17** Carrying out pneumatic testing and purging as per specifications and approved procedures, providing all tools & tackles, instruments, manpower and other related accessories for carrying out the testing of pipes.
 - 3.18** Supply, fabrication & installation of RCC route marker, Pole marker with foundations, Plate markers, valve chamber etc. as per the directions of the EIC/Owner's representative.
 - 3.19** Nitrogen purging (including supply), commissioning and gas charging in the tested PE line shall be done as per the approved procedure.
-

- 3.20** Restoration of existing ground features such as grass/turfing, paving, roads, drains, concrete, floral beds, fencing, tiles, marbles, flooring masonry etc. to original condition and to match with adjoining conditions, functionally and aesthetically up to the entire satisfaction of Owner / Owner's representative /any other third-party agency designated by owner and local authorities, failing which, it will be done at the risk and cost of the contractor. Obtaining No Objection Certificates for the restoration work done from the concerned authorities.
- 3.21** Returning surplus material to Owner stores after obtaining clearance from TPIA/Consultant/ Owner, reconciliation of free issue material/consumables.
- 3.22** Handing over the completed works to owner for their operation/use purposes.
- 3.23** Rectification of defects arising due to poor workmanship during defect liability period of pipelines/installations handed over to Owner.
- 3.24** Preparation and submission of all documents like Pit wise As graph, As-built drawings, details of crossings, utility graphs, PE cards for service line and deviation statements on completion/commissioning of work by way of drawing, sketches and tables in soft & hard copy.
- 3.25** Providing adequate manpower for carrying out laying for PNG installation for emergency cases as and when required. Providing adequate manpower for material for carrying out laying for PNG installation for emergency cases as and when required, as per instruction of EIC.
- 3.26** Following activities are also in contractor's scope:
- Receive Customer's complaints logged during MDPE Laying.
 - Attend and Carry out joint technical feasibility survey for requests and resolve the complaint.
 - Maintain and update the complaint status.
- 3.27** Carrying out Ground penetrating Radar (GPR) survey from recognized agencies to determine the underground utilities/services such as existing pipelines, cables electrical/communication), conduits, U/G drainage, Sewers, tunnels, subways foundations etc. for deciding optimum feasible route and depths for laying the pipelines based on the route plans.
- 3.28** Repair and Maintenance of PE pipeline as excavation, leakage arrest, jointing and restoration of any size including supply and installation of all fittings required in case of third-party damage after commissioning. PE Pipe required shall be issued by Owner as free issue material.
- 3.29** Any other activities not mentioned/covered explicitly above, but otherwise required for satisfactory completion/operation/ safety/ statutory/ maintenance of the works shall also be covered under the Scope of work and has to be completed by the Contractor within specified schedule at no extra cost to Owner.

This technical specification defines the basic guidelines to develop an acceptable design and suitable construction methodology for carrying out different activities listed out in the schedule of rates of this tender.

Compliance with this specification and/ or approval of any of the Contractor's documents shall in no case relieve the Contractor of his contractual obligations

Any other activities not mentioned/covered explicitly above, but otherwise required for satisfactory completion/operation/ safety/ statutory/ maintenance of the works shall also be covered under the Scope of work and has to be completed

by the Contractor within specified schedule at no extra cost to Owner.

4.0 MATERIAL, MANPOWER, EQUIPMENT AND MACHINERY

Material to be supplied by Owner as Free Issue.

Unless otherwise specified, Owner will only supply material such as PE – pipes (125, 63, 32 & 20 mm OD) and Service regulator excluding cover box and all materials other than Carrier Pipe shall be supplied by contractor as per attached technical specification to complete the laying of gas main and service pipelines.

The free issue material shall not be procured from any other source by contractor.

Material reconciliation statement of free issue material duly certified by Owner and PMC shall be submitted to CUGL on monthly basis.

Material to be supplied by the contractor:

The supply of items as indicated in SOR but not limited to shall be strictly as per relevant technical specifications, Datasheet and QAP enclosed with the Tender and as per guidelines of various clauses of SCC and SOR.

All materials shall be handled safely and stored in a permanent, covered, lockable store/ ware house preferably near site in such a manner as to prevent any damage to the materials from scratching, gouging, indentation, excessive heat or by contact with any sharp objects or chemicals. The PE pipes and fittings shall be stored in covered storage to protect material from sunshine, rain etc. Pipe should be stacked with clearance from ground level.

4.1 Backfilling Material

The contractor shall be responsible to arrange the supply of approved coarse sand (size 0.6 - 2 mm as per IS 383) free from any impurities like clay, mica, and soft flaky pieces, as per the instructions of EIC /Owner's representative. For supply of sand in trench for rocky terrain, no separate charges are payable and is included in rates. Also supply of sand in valve chambers, Normal surface & built up surface, if required, as per the instructions of EIC is not separately payable.

In case specified trench, depths are not achieved or if directed by Engineer-In Charge Contractor has to provide concrete casing pipes/ slabs or cement concrete, without any cost implication to Owner.

Other materials: The contractor shall supply the following items wherever required:

- All materials required for framework, trench support and temporary trench Crossings.
 - All sign boards, barricades, tin sheets, lighting arrangement and protective equipment.
 - All minor items not mentioned in the specification but necessary for the satisfactory completion and performance of the work.
 - Material required for installation of valve chambers.
 - GI, Half Round Concrete Sleeves.
 - Permanent markers
 - Warning Mat
-

4.2 Manpower

The contractor shall provide the skilled labour, tools, material and equipment necessary for the proper execution of the work.

4.3 Equipment, Machinery & Tools

This will include but is not limited to the list of specialized items included in Annexure# I

All vehicular type machinery shall be in good working order and shall not cause spillage of oil or grease. To avoid damage to paved surfaces, the Contractor will provide pads of timber or thick rubber under the hydraulic feet or outriggers of machinery.

Contractor must also have to arrange his own equipment for restoration work like water tanker and jumping jack compactor for compaction of backfilled trenches and roller and other required equipment/ machinery for asphaltting/ road works.

In case there is non-availability of approved equipment's, tools and tackles during the work at site, suitable penalties, as per special terms and conditions of the contract, will be levied and deducted from the running bills.

4.4 Acquisition, Receipt & Storage of Materials

The Contractor shall collect all materials from CUGL during stores working hours following all documentation procedures laid down and as directed by the CUGL/PMC. The Contractor shall carry pipe in such a manner as to preclude damage during transportation and handling. PE pipes supplied in straight lengths may be carried in Straight pipe racks.

The contractor shall at the time of receipt of material physically examine all materials and notify the EIC immediately of any damage or defect noticed by the contractor. Any damage not so recorded will be deemed not to have existed at the time of receipt of material by the contractor and the cost of repair or replacement or rectification shall be borne by the contractor. Any material once issued from CUGL store, if found in non-working condition at site shall be brought to the notice of EIC with PO reference in written within 15 days and after subsequent approval shall return defective material in CUGL stores within 30 days.

If delay is more than 30 days and material is under warranty, the material will be accepted with a penalty, else the material will not be reconciled and amount of the same will be deducted from bills. Penalty shall be levied as per SCC. The contractor shall ensure that no defective material shall be returned to store at the time of closure of contract. The format for defective materials returning to stores will be made available by EIC.

The contractor shall maintain locked store preferably near at site so that all the materials are stored in such a manner so as to prevent any damage to the materials from scratching, gouging, indentation, excessive heat or by contact with any sharp objects or chemicals. The PE pipes and fittings shall be stored in covered storage to protect material from sunshine, rain, water logging etc. The contractor shall make adequate security arrangements for the stacked material & any loss to the material on account of theft on improper storage is attributable to the contractor.

The Contractor shall maintain log book at their respective stores stating issue and availability of free issue material at a given day. Further, it is mandatory that the contractor is required to undertake and submit inventory details of free issue and purchased materials on monthly basis to Owner/ Owner's representative as per the approved format of the owner. The inventory details shall be in correlation with the Daily progress chart and material reconciliation sheet.

In case of non-submission of material reconciliation on first week of every month, applicable penalties shall be levied as per SCC from the running bills. In case if shortage in free issue material is observed at the time of quarterly physical verification by CUGL,

equivalent value of material found short shall be withheld from running bills, same shall be released after settlement of free issue material.

5.0 PROGRESS OF WORK

The contractor shall proceed with the work under the contract with due expedition and without delay. The EIC may direct in what order and at what time, the various stages or parts of the work under the contract shall be performed. Contractor has to regularly submit daily progress reports, weekly progress reports, graphs with utilities, testing reports, material consumption and inventory reports, deviation statements, completion schedule etc.

6.0 APPROVALS & PERMISSIONS FOR PIPELINE LAYING

Contractor has to obtain permissions from statutory bodies for laying of pipelines. Statutory bodies in this case are ,Municipality PWD, NHAI, CPWD, AAI, Indian railways, Local development authority, RWA, Individual housing and any other government agencies who maintain the public lands and accord permissions for laying of the utilities. The contractor shall obtain demand note (road restoration charges) from these statutory bodies. Contractor shall ensure that the road restoration charges are to the minimum against the work to be carried out. CUGL may return back the demand note, if the Road Restoration charges are not found reasonable then OWNER shall not be liable to pay any Road Restoration Charges against the same to Concern Authority.

However, CUGL will pay the road restoration / Departmental charges / security deposit/ Bank guarantees (reimbursement against documentary evidence) for getting the clearances from statutory bodies. It is the contractor's responsibility to inform and co-ordinate the concerned local authorities and also other utility agencies before and after the commencement of work at site. To ensure smooth execution of the work on a day-to-day basis, the contractor has to liaison with respective authorities. The contractor shall plan and ensure that work taken up under a single permission shall be completed within the stipulated time period and revalidation process is avoided. No separate liaison charges are liable to OWNER for revalidation cases.

It is the responsibility of the contractor to obtain "No Objection Certificate" (NOC) from land owning agencies/ Statutory bodies after completion of the restoration to their satisfaction and getting released the security deposit/ bank guarantees submitted by CUGL for obtaining permissions on production of documentary evidence. Separate payment in running meters will be made on account of approvals/ permissions as per the SOR. In case of-any deviation/ additional laying, CUGL shall pay the additional Road Restoration Charges only after receiving of revised estimate and further to written confirmation from the Engineer in-charge.

On behalf of the Owner, contractor shall prepare in advance and submit the proposed route plan complete in all respect and well ahead of time so that the actual construction work is not delayed because of approval/ inspection/ permission by concerned authorities. Further, the contractor shall also coordinate with the relevant authorities for necessary approvals of these proposed pipeline route drawings/ certificates. The inspection of work by statutory authorities shall be the responsibility of the contractor without any extra cost to CUGL.

In case contractor delays laying of pipeline work under a single permission, the work or part of work may be offloaded to some other contractor on his risk and cost. Any change / addition required to made to meet the requirements of the statutory authorities shall be carried out by the contractor without any extra cost to CUGL. The inspection and acceptance of the work by statutory authorities shall however, not absolve the contract from any of his responsibilities under this contract.

7.0 REFERENCE SPECIFICATION, CODES AND STANDARD

The contractor shall carry out the work in accordance with the requirement of latest relevant applicable standards, this specification, Owner's Engineering Standards; relevant Oil Indian Safety Directorate (OISD) norms, PNGRB Regulations, ASME B31.8-Gas Transmission and Distribution Piping Systems; Australian Standard 3723-Installation and Maintenance of Plastics Pipe Systems for Gas; and the American Gas Association Document - Purging Principles and Practice. ISO-4437/JS: 14885 for underground polyethylene pipes and OWNER's approved procedures.

Should the contractor find any discrepancy, ambiguity or conflict in or between any of the standards and the contract documents, then this should be promptly referred to the Engineer-In-Charge (EIC) for his decision, which shall be considered binding on the contractor.

8.0 QUALITY OF WORK

All works carried out under this contract shall confirm to applicable standards, codes of practice, construction procedures and other technical requirements as defined in the technical specifications.

The manpower deployed on the respective activities shall be adequately trained & shall have necessary skills to execute / supervise the work. However, the assessment on the qualification of the personnel shall be at the discretion of EIC.

Fusion operators and other skilled personnel shall be approved by Owner/ Owner's representative and identification cards duly signed by EIC shall be issued to them. Only those personnel who are approved by shall be allowed to execute the critical activities like electro fusion jointing of MDPE pipes & fittings. CUGL may provide training and certification on chargeable basis where the cost shall be borne by contractor.

9.0 SAFETY

The Contractor shall conform to the safety requirements outlined elsewhere in the tender document. In addition, the Contractor shall observe safe working practices in the storage and handling of cleaning fluids, flammable fluids, etc., and ensure smoking or naked flames are not permitted in the vicinity when these materials are being used.

Trench walls shall be battered with sufficient slope in order to minimize a trench collapse. Where there is a danger of an earth slide or collapse, the trench shall remain open for the minimum time possible with proper barricading. The Contractor is to ensure that no person enters a trench, which is of a depth of 1.5 meters or greater, unless the trench has adequate shoring or the sides are battered to such an extent as to prevent a trench collapse.

The Contractor shall also protect all work sites with warning signs, barricades and night lighting. The Contractor shall inspect all fenced excavations daily, and maintain them in good order.

The trenches/ pits shall not be kept open in night times. However, in case the same is essential the same shall be properly barricaded with proper lighting arrangements & manned.

The Contractor shall provide PPE's like helmets, safety shoes, etc. to the labour which are necessary for safe working practice.

Any accident causing injury to any person or damage to property or equipment shall be reported to the EIC and the cost of repair / replacement of the damage equipment shall be borne by the contractor. Where the EIC determines that the work is being performed by the Contractor in an unsafe manner, he may suspend the Work until corrective action

is taken by the Contractor.

PPE, Continuous Barricades and caution tapes along the trenches as per approved drawing in tender, Use of Safety Boots, Hand gloves, Reflective jackets, Hard hats(helmets), Safety shoes, eye and ear safety equipment, Fire extinguishers and as per the detailed scope of work & HSE specifications. Contractor shall be paid as per SOR, measurement sheet of PE laying should also include length of barricading. Refer relevant drawing attached in this tender . For further details Refer "Special conditions of Contract" & SOR.

10.0 ROUTE SURVEY

Planning, detailing the size, route survey drawings, identification of underground utilities, foreign pipelines, crossings, and location of valve chamber, DRS as well as service line location is in scope of contractor.

10.1 Mainlines

The final alignment of mainlines will be worked out at site in consultations with the Owner/ Owner's representatives after route survey and trial pits, at contractor cost. Any change in routing from the issued drawings due to site constraint will be notified to EIC & his specific written approval shall be obtained before carrying out the job.

10.2 Service lines

Consultant/ Third Party Inspection Agency and the contractor will conduct a joint survey at each probable premise/ housing colony/ pockets/ area to be supplied with Natural Gas. The survey record will note customer's detailed potential gas supply points, proposed regulator positions and estimates of material quantities. The contractor's representatives will make sketch of the agreed pipe routes.

The contractor will be responsible for contacting the customer and making the necessary arrangements for access and appointments to carry out the work. Contractor shall maintain job card and complaint books at site. Owner will not be responsible for time lost due to failed appointments or disputes with customers.

11.0 ORGANISATION STRUCTURE

Contractor shall designate Project Manager / Coordinator who will be responsible to interact with CUGL/ Consultant/ TPIA and authorized to attend review meetings, receive material, authorized to sign documents, claims and receive payments etc. Contractor shall employ a Project Manager or Coordinator and site Engineer on company roll. The Project Manager/ Coordinator must have qualification of BE Mech. /Diploma in Mech. Engg. with min. 3/5 years & Site Engineer must have minimum Diploma in Mechanical Engineering with 3 years of work experience in gas pipe line job. Project Manager or Project Coordinator shall be single point of contact for all the works and must represent company in the review meetings.

All construction work will be carried out as per direction of CUGL/PMC, and this will be the primary point of contact between the contractor and Owner on site. All work will be issued and sanctioned through the EIC and site control exercised by Site Engineers. The contractor shall ensure that technical quality standards are maintained, that construction is carried out cost effectively and that a good customer and public image is maintained for Owner.

The contractor will deploy his own supervisors as directed by site engineers/EIC. These personnel will be reporting to the Site Engineer for monitoring construction standards and for ensuring that all technical requirements are met for the job being carried out. The contractor's supervisor(s) will have day-to-day liaison with the Site Engineer, and will provide the Site Engineer with technical reports and audits, and other management information as is required on work progress and construction quality standards.

The contractor's supervisor shall have mobile telephones to ensure that they can be contacted at all times. The contractor will also nominate one person who can be contacted if necessary, in odd hours, for the duration of the works. The contractor's supervisor will have access to transport at all times to allow them to visit sites and attend meetings with Owner. Supervisor shall attend to normal day-to-day issue of work instructions, communication between Owner and the contractor's supervisor and the Site Engineer.

Contractor shall maintain a Customer Care Centre, Project Site Office, and Material Store in their allotted site with following facilities:

- Telephone, Mobile Phones, Fax machines, Printers/ Scanning/ Xerox machines, Computers with internet facility.
- One Nos. - Four-wheeler with driver, he shall be well equipped with tools and tackles for attending any emergency complaints and ongoing execution work.
- On award of the contract, the contractor shall establish and submit documentary evidence for above, which will be verified by the CUGL/PMC before award of the W.O.

12.0 STRUCTURES, SERVICES AND OTHER PROPERTY

12.1 Location of Underground Utilities

The contractor shall locate all buried utility pipes, underground cables, water mains and other obstructions intersecting or adjacent to the Works, and shall make available the necessary labour to expose and record the depth of cover over all obstructions in advance of excavation. This shall be done far enough in advance of excavation to facilitate gradual change in grade or position found necessary to clear any obstructions.

In addition, the contractor shall excavate trial pits as necessary to determine the pipe route. The number of trial pits will be agreed with the Site Engineer in advance of any excavation. In any event, trial pits shall be made at intervals of a maximum of 30 meters. Restoration of the abandoned trial pits and trenches shall be the contractor's responsibility. No payments shall be made for such type of jobs. The trial pits shall be excavated to minimum depth of 1.5 meters so as to locate any utilities present in the trench.

It is contractor's responsibility to interact with other utility agencies regarding their existing utilities and finalize the route along with these agencies and Owner/ Owner's representative.

There will be no additional payments in respect of abandoned trenches incurred because of insufficient or inadequate trial pits, or any associated loss of time or delays.

Contractor must ensure that before starting the execution of laying of pipeline, the intimation/information must cascade to all utility's agencies seeking the information about the existing utility in the proposed route.

12.2 Protection of Structures and Utilities

The Contractor shall at his own cost support and protect all buildings, walls, fences or other structures and all utilities e.g. Electrical cables, Telephone Cables, Water pipelines, Sewer pipelines etc., and property which may be damaged as a result of the execution of the works. He shall also comply with the requirements in the specification relating to protective measures applicable to particular operations or kind of work. Special care shall be taken while laying of pipelines near the trees.

12.3 Interference with Traffic, Street Drainage and General Public

The Work shall be executed in such a manner so as to cause a minimum inconvenience to persons using public or private roads, lanes, thoroughfares, walkways, rights-of use or passages through which the Works are to be executed. The trench shall be back filled; compacted, leveled and extra soil shall be removed immediately after laying of pipeline to avoid public inconvenience. Closure of roads, etc., shall not be permitted without the approval of the EIC.

The Contractor shall comply with all local Authorities requirements to traffic and keep roads open to traffic and maintain access to and within any private property.

Wherever the pipe route crosses driveways, access tracks or entrances to private properties the Contractor shall give the owner, occupier or relevant authority at least 24 hours prior notice of intended commencement of excavation and shall be restricted to pass through.

The Contractor shall not use a private driveway, access track or entrance without the prior approval of the EIC in any circumstance.

The Contractor shall provide suitable access wherever necessary in the form of temporary bridges, culverts, flumes, etc., of a size and type approved by the EIC.

The Contractor shall comply with all relevant road Laws. Where limits and/or speed limits have been placed in the vicinity of the Works, the Contractor shall provide for the necessary movement of plant and equipment in accordance with the requirements of the relevant authority.

The Contractor shall not obstruct any drainage pipes or channels in any road but shall divert them wherever necessary and use all proper measures to provide for the free passage of water.

The Contractor shall handover the completed works after proper cleaning of the site.

The contractor shall conduct his operation at all times, with a view to minimize as far as practicable noise and other objectionable nuisances (e.g. oil leakage, spillage, debris etc.)

13.0 TRENCHING

The schematic drawing with the details of trench is enclosed in the tender.

The Contractor shall perform the excavation works so as to enable the pipe to be laid in conformity with the levels, depths, slopes, curves, dimensions and instructions shown in the Drawings, Specifications or as otherwise directed by the EIC.

Contractor shall excavate and maintain the pipeline trench on staked center line as per approved drawing taking into account the horizontal curves of the pipelines.

While trenching, care shall be taken to ensure that all underground structures and utilities are disturbed to the minimum. Suitable crossing shall be provided and maintained over the ROU wherever necessary to permit general public, property owners or his tenants to cross or move stock or equipment from side of the trench or another.

Trenching shall be made with sufficient slopes on sides in order to minimize collapsing of the trench. On slopes wherever there is danger of landslides, the pipeline trench shall be maintained open only for the time strictly necessary. Owner may require excavation by hand, local route and detouring and limiting the period of executing of the works. Before trench cuts through water table, proper drainage shall be ensured, both near the ditch and ROU in order to guarantee the soil stability.

The Contractor shall ensure that trench bottom is maintained in the square form as far as possible, with equipment, so as to avoid/minimize the hand grading at the bottom of the trench. The Contractor shall do all such handwork in the trench as required to free the bottom of trench from loose rock, pebbles and to trim protruding roots the bottom and sidewalls of the trench.

13.1 Depth of Trench

The minimum depth of cover shall be measured from top of pipe to the top of undisturbed surface of the soil or top of the graded working strip or top of road or top of rail, whichever is lower.

In case of crossing of water bodies, the minimum depth shall be measured from the top of the pipe to the bottom of Scour level.

The depth of the trench will be such as to provide minimum cover as stipulated below:

For Distribution main and service lines

Minor Water Crossing/Canal	2.0 Meter
Uncased/Cased Road Crossing	1.2 Meter
Rail/Road Cased Crossing	1.7 Meter
Normal Areas	1.0 Meter

The minimum depth may be greater than as mentioned above as may be required by Government/Public authorities under jurisdictions. The Contractor shall perform such work without extra compensation, according to the requirement of concerned authorities.

Also, in case of Drains/ Culverts/ Utilities crossing through open cut where excavation cut is more than 1.5m, the extra excavation is inclusive in the laying rates. No separate payment is chargeable for extra excavation and includes backfilling as well.

In case, the depth could not be achieved due to practical problems and the same is demonstrated, EIC after examining thoroughly and considering the codes and standards may allow the contractor to provide suitable protection by way of concrete casing pipes or slabs. No separate payment will be done.

13.2 Width of Trench

The width of the trench shall be wide enough to provide bedding around the pipe as specified and to prevent damage to the pipe inside the trench. Unless otherwise directed by the EIC and where ground conditions permit, the minimum distance from the inside edge of the trench wall to the outside of the pipe shall be as per relevant drawing attached in this tender..

13.3 Trench Base

The trench bottom shall be cut or trimmed to provide a uniform bedding for the pipe and shall be free from stones, metal, wood, vegetation, clods of earth or other debris before placement of the pipe.

In case trenching is done in rocky terrain, a bedding of soft soil or sand shall be provided in the trench base at no extra cost to the satisfaction of EIC.

13.4 Hard Rock:

Hard rock is defined as trench material with a single piece of rock, dimension exceeding 1.0 m in any direction, which requires cutting only by use of chisel/ pneumatic chisel/ drill or sledge hammer or removal of the same by additional excavation technique approved by EIC. Additional rates shall be payable for hard rock excavation as per the SOR over and above the pipeline laying rates. Excavation through soil mixed with small boulders that have been used for a road base will not be considered as hard rock for the purpose of payment.

13.5 Clearances

Unless otherwise approved, the following clearances shall be maintained between the external wall of the gas pipe and the external surface of other underground assets/utilities in the vicinity of the Works.

- 150 - 300 mm where the gas pipe crosses other assets/utilities, etc., for electric cables, the clearance shall be 300mm minimum or special protection shall be provided as per approval of EIC.
- 300mm where the gas pipe is on a similar alignment to the other assets/utilities.

Where the above clearances cannot be achieved, or in other special circumstances, the EIC may approve/specify protection with concrete/MS coated pipe, etc. The protective material shall be supplied and installed by the Contractor at his cost subject to discretion of EIC.

13.6 Under Ground Interferences

The Contractor shall locate and expose manually all underground facilities if any during trenching. Safety barriers shall be erected along the trench to prevent any damages or accident. On locations where pipeline is laid under the existing facilities and near the approaches of the crossing, the trench shall be gradually deepened to avoid sharp bends.

All sewers, drains, ditches and other natural waterways encountered while trenching shall be maintained open and functional by providing proper temporary installations if required. Suitable dewatering pumps shall be deployed to dewater, if required.

Whenever it is permitted by Authorities and /or Owner to open cut paved road crossing, or where the line is routed within the road pavement, the Contractor shall remove the paving in accordance with the restrictions and requirements of the authorities having jurisdiction thereof as directed by Owner. After laying the pipeline, backfilling shall be immediately performed, and all the areas affected connected with the excavation works shall be temporarily restored.

In case of damage to any of above referred structures/utilities the Contractor shall be responsible for repairs/replacement at his own cost, which shall be carried out to the satisfaction of concerned authorities, resident and Owner.

13.7 Others

Throughout the period of execution of such work, the Contractor shall provide and use warning signs, traffic lights or lanterns, barricades, fencing, watchman etc. As required by the local authorities' jurisdiction and/or Owner.

For all roads, paths, walkways etc. which are open-cut, the Contractor shall provide temporary diversions properly constructed to allow the passage of normal traffic with the minimum inconvenience and interruptions.

The paving shall be resorted to its original condition after the pipeline is installed.

The Contractor shall excavate to additional depth at all the points where the contour of the earth may require extra depth, or where deep trench is required at the approaches to crossings of roadways, railroads, rivers, streams, drainage and ditches without any extra cost implication to Owner.

The Contractor shall excavate all such aforesaid depths as may be required at no extra cost to Owner. The trench shall be cut to a grade that will provide a firm, uniform and continuous support for the pipe.

The Contractor shall take conducive measures to ensure the protection of underground utilities as per the instructions of Owner or relevant authorities.

Where the pipeline crosses underground utilities/structures, Contractor shall first manually excavate to a depth and in such a manner that the utilities/structures are located, then proceed with the conventional methods.

The locations, where the pipeline has to be laid more or less parallel to an existing pipeline cable and/or other utilities in the Right-of-way the Contractor shall perform the work to the satisfaction of the Owner of the existing pipeline/cable/utility. In such locations, the Contractor shall perform work in such a way that even under the worst weather and flooding conditions, the existing pipeline/utilities remain stable and shall neither become undermined nor have the tendency to slide towards the trench.

13.8 Bedding

The Contractor shall ensure that the pipe when placed in the trench is supported and surrounded by a bed of screened excavated soil, which shall be stone free and have a maximum grit size of 5mm, in order to ensure no damage occurs to the pipe. However, in case of rocky soil the bedding shall be done with approved good quality packing sand subject to the approval of the Site Engineer. The packing sand shall be placed to a minimum thickness of 150mm around the pipe in case of rocky terrain.

Unless directed by the EIC the quantity of bedding and surrounding sand shall confirm specifications. There shall be no void space in the packing sand around the pipe.

14.0 LAYING

14.1 Main line

Laying of PE pipelines shall be commenced only after ensuring proper dimensions and clean surface of the trench. The trench bottom shall be free from the presence of cuts, stones, roots, debris, stakes, rock projections up to 150mm below underside of pipe and any other material, which could lead of perforation/tearing of the pipe wall. After ensuring above, the PE pipe coil shall be uncoiled smoothly through proper equipment's/care before laying pipe inside the trench ensuring no damage to pipe.

The contractor must ensure that Pipe caps are provided before lowering of Pipeline. The trench after this can be released for back filling leaving adequate lengths open at the ends for jointing.

Contractors shall ensure open ends of pipe placed in the trench shall be securely capped or plugged to prevent the ingress of water or other matter. The Contractor is to ensure that nothing enters inside the pipe during the laying process as this could cause a future blockage or regulator malfunction due to dust, etc.

In case of open cuts and moiling, where two pipes are to be laid parallel in same trench or same pits, 30% of the respective SOR of the lower size pipe for the laid length shall be paid additionally to the rates applicable to the higher pipe size.

As per PNGRB, Valves are to be provided at every Km in PE main pipeline. The above spacing, however, may be increased or decreased based on risk assessment and to allow location of valve at an easily accessible location as directed by the EIC.

Valves shall be installed at locations shown in the Design Plan or as directed by the EIC and joined with PE pipes by electro fusion techniques. The valves shall be placed on a concrete square block at the bottom to achieve equivalent support of the incoming and outgoing pipe.

Laying graphs/As-graphs with details of depth, length, offsets from minimum three (03) fixed different references, other utility crossings, fittings, sizes of the casing pipe used for the pipeline shall be prepared on daily basis and to be submitted to CUGL representative/ EIC for approval. These details will further be incorporated in to As-Built Drawings.

Pipe may pass through an open drain or nallah with prior approval from EIC. Where this is permitted, the PE pipe shall be installed inside a casing pipe (i.e. HDPE, GI concrete) for protection. Payment will be made as per relevant SOR item The Casing material shall be procured and laid by the Contractor as per technical specification with prior inspection and approval of the EIC for the quality of material. In general, the GI Sleeve material specification shall be confirming to IS 1239 (Heavy Duty) specification of reputed make under the vendor list attached in tender & approved by EIC; In case of service line laying, where the excavated pit for mainline is used for laying of service line, the length of service pipe laid in the same pit and vertical pipe which rises out of the ground with transition fittings shall be paid as per SOR. The contractor shall excavate a minimum pit of size 0.5 meter x 0.5 meter (L X W) on any kind of surface along the wall at the customer premises for the service pipe which rises out of the ground with transition fittings through GI pipe sleeve/ Half Round Concrete sleeve. This excavation along with other work necessary to break through the walls of the obstruction, insertion of PE pipe, sealing of the annulus between the pipe and the sleeve, sleeve and the wall, installation of sleeve, making of pedestal as per relevant Drawing No min. Size 300 x 150 x 150 mm for GI Sleeve, min. Size 550 x 230 x 150 mm for Half Round Concrete Sleeve. and simultaneous restoration of these pits shall be deemed included in the laying rates of pipes respectively. GI Sleeve / Half round concrete sleeve rates are included in PE Laying rates of relevant SOR item ,No separate payment shall be paid by the owner . The material shall be inspected by TPIA / Consultant before installation. Also, the material test certificates, inspection reports approved by TPIA/ Consultant shall be submitted at the time of submission of bill. Any installation without inspection & approval may lead to penalties as per Special Conditions of Contract.

In case of service lines, EIC shall decide either half round concrete sleeve or GI pipe sleeve shall be installed at any particular site depending upon site condition. The half round concrete sleeve shall be preferred over GI Sleeve, however in case where the installation of half round Concrete Sleeve is not possible due to technical feasibility and site conditions, GI sleeves shall be installed only after written approval from EIC. The rate of GI Sleeve / half round concrete sleeve shall be included in laying of 20/~~3232~~ mm dia. As per SOR depending upon surface conditions. The details are mentioned below:

14.2 GI Sleeve

The contractor shall supply the minimum dia. Size of 2.5" & 3", 300 mm in length, GI sleeves (Heavy Duty reputed make) respectively for domestic & commercial / industrial installations. The material shall be inspected by TPIA / Consultant before installation. The material test certificates/ inspection reports shall be submitted at the time of submission of bill. The material shall be inspected by TPIA/ PMC before installation.

A bending tool shall be used to bend the GI sleeve pipe so that it has the appropriate curvature and is free of kinks. The installation of GI sleeve for service lines shall be done by sealing the annulus between pipe and sleeve, firm fixing of the GI sleeves by concrete mix pedestal, clamping, sand filling, etc.

The vertical portion of the sleeves shall be fixed to the wall of the premises in a secure manner. The Service lines shall be installed in accordance with the drawing enclosed in the tender.

14.3 Half Round Concrete Sleeve

The installation of Half Round Concrete sleeve for service lines shall be done by sealing the annulus between pipe and sleeve, firm fixing of the Concrete sleeves by concrete mix pedestal, clamping, sand filling, etc. Half round concrete sleeve shall be made as per attached drawing and as per instruction of CUGL/PMC/TPIA. The dimensions shown are tentative and may vary depending upon the site conditions. The material shall be inspected by TPIA / Consultant at the fabrication stage & prior to final dispatch at site for installation. The material test certificates/ inspection reports shall be submitted at the time of submission of bill.

14.4 Crush Guard/ half Round Concrete Sleeve: - (For O&M and Project)

The installation of pre-cast RCC crush guard over Half Round Concrete Sleeve/ Pedestal shall be done by installing it resting on wall of building by fixing it with grouting nut and bolts in wall that may be detached during the event of leakage/testing. The material shall be inspected by TPIA / Consultant at the fabrication stage & prior to final dispatch at site for installation. The material test certificates/ inspection reports shall be submitted at the time of submission of bill.

The Crush Guard shall be installed in accordance with the drawing enclosed in the tender as per instruction of CUGL/PMC/TPIA.

14.5 LAYING OF SERVICE LINE IN PROJECT AND O&M AREA:

O&M area shall be defined as those areas where PE line is already charged and handed over to owner.

Laying of pipeline (for 20 & 32mm) in all type of surface i.e. all kinds including Kuccha, metal, concrete (PCC/RCC), bituminous, tiled, brick lined etc. after racking up of hard surface of any type by any methodology. Roads, Pavement, Footpaths etc. shall be made memorable once the pipeline is laid. Supply & installation of GI Sleeve / Half round Concrete sleeve is included in laying rates of 20mm/32mm. The rate includes liasoning with statutory bodies and no separate rates are payable. Wherever service lines are to be laid after dismantling nallah / drain, additional cost for dismantling and repairing shall be payable under the relevant SOR.

All service lines left out initially during mainline laying and laid by same/other contractor after gas charging shall be paid as per relevant SOR item.

14.6 PE PIPELINE LAYING (20MM / 32 MM / 63MM) IN ALREADY EXCAVATED TRENCH IN BUILDER SEGMENT

Scope includes laying of MDPE pipeline in already excavated trench with or without casing ; insertion of the carrier pipe in casing pipe (on case to case basis) laying of warning mat electro-fusion of joints and re-installation of pre-cast slabs as per specification after instruction of EIC / Site Engineer of Owner.

In Case sand filling is also required, shall be done as instructed by CUGL/PMC/TPIA representative and paid as per relevant SOR item.

15.0 JOINTING OF POLYETHYLENE PIPE

The procedure for jointing of PE pipe, valves and fittings machines is attached as Annexure #2 and as per Standard Specification for ELECTROFUSION FOR PE PIPES AND FITTINGS which is a part of tender document. Only Bar coded ~~into~~ electro-fusion machines (Automatically Readable) which can read the bar code of the fittings and valves

automatically shall be used for joining of the PE pipes/ Valves & fittings. Manual feeding Electro-fusion machines are not acceptable for jointing purpose. The contractor has to submit the certificate of calibration of electro-fusion machine at the time of start of work and at fixed intervals as per the instructions of Owner. Contractor shall ensure that the machines are always available at site. No stoppage of work due to the non-availability of machines shall be allowed.

The contractor shall flush the Pipeline with air to remove dust, water, mud etc. before fusing the joints. Before jointing, the Contractor shall place packing sand under the pipes on both sides of the joint to keep the pipes in line and at the correct alignment during the jointing process. The jointing process shall start only after Alignment clamps with the correct size are aligned with the pipe and coupler during the electro-fusion cycle.

The Contractor shall ensure that polyethylene pipe is only cut with an approved plastic pipe-cutting tool (refer Annexure-I). Before fusion is attempted, the contractor shall remove the oxidized surface of the pipe using Universal Scrapper up to 63mm/ Rotary Peeler for 63 mm and above before inserting into the electro-fusion coupler. The tool must remove a layer of 0.1mm to 0.4mm from the outer surface of the polyethylene pipe. No fusion will be allowed without clamping device and the approved cutting tools (Hack saw shall not be allowed for cutting the pipe).

The contractor has to supply all the consumables required for carrying fusion of the joints (like tissue paper, napkin, acetone etc.).

If, upon inspection, the EIC determines a joint is defective, Contractor shall remove the joint by an approved method. The cost of replacing joint shall be borne by the Contractor including the cost of pipe and fittings removed.

For electro-fusion joining, the contractor must bring own tools, tackles and equipment. Only, approved Jointers shall carry out fusion of all joints. Contractors shall provide the list of jointers to be used on the job and make arrangements for Qualification Testing of the jointers in presence of Owner / Owner's representative as per the standard procedures. All approved Jointers shall bear identity cards signed by Owner / Owner's representative during fusion job and shall furnish the same on demand by Owner / Owner's representative. Applicable penalties shall be levied, in case; it is found that fusion is being carried by non-qualified jointers as per the provisions made in Special Conditions of the Contract.

Contractor shall arrange generator along with voltage stabilizer for power supply to fusion machine. Taking power connection from electric poles, connections without written permission from the concerned authorities or residential premises is strictly not permitted.

16.0 BACKFILLING

Backfilling shall be done after ensuring that appurtenance have been properly fitted and the pipe is following the trench profile at the required depth that will provide the required cover and has a bed which is free of extraneous material and which allows the pipe to rest smoothly and evenly. Dewatering shall be carried out prior to backfilling. No backfilling shall be allowed if the trench is not completely dewatered.

Prior to backfilling it should be ensured that the post padding of compacted thickness 150 mm is put over and around the pipe immediately after lowering where required.

Backfilling shall be carried out immediately after the post padding where required has been completed in the trench, inspected and approved by Owner/ Owner's representative, so as to provide a natural anchorage for the pipe avoiding sliding down of trench sides and pipe moment in the trench. If immediate backfilling is not possible, a padding of at least 300mm of earth, free of rock and hard lumps shall be placed over and around the pipe and coating.

The backfill material shall contain no extraneous material and/or hard lumps of soil, which could damage the pipe and/or coating or leave voids in the backfilled trench. In case, it is required and directed by CUGL/PMC/TPIA screening of the backfill material shall be carried out with specified equipment before backfilling the trench.

The surplus material shall be neatly crowned directly over the trench and the adjacent excavated areas on both sides of the trench to such a height which will, in Owner/Owner's representative opinion of provide adequately for future settlement of the trench backfill during the maintenance period and thereafter. The down shall be high enough to prevent the formation of the depression in the soil when backfill has settled into its permanent position should depression occur after backfill, Contractor shall be responsible for remedial work at no extra cost to Company. Surplus material, including rock left from this operation shall be disposed off to the satisfaction of landowner or authority having jurisdiction at no extra cost to Owner.

Where rock, gravel, lumps of hard soil or like materials are encountered at the time of trench excavation, sufficient earth, sand or select backfill materials shall be placed around and over the pipe to form a protective cushion extending at least to a height of 150 mm above the top of the pipe. Select backfill materials for padding that area acceptable shall be soil, sand, clay or other material containing no gravel, required selected backfill material has been placed, provided the rock or lumps of hard soil. The padding earth shall not contain any stones, i.e. the earth shall be screened for sand padding of the Pipeline in order to avoid damage to the pipeline. Contractor shall carry out all these works at no extra cost to Owner. Loose rock may be returned to the trench after the required selected backfill material has been placed, provided the rock placed in the ditch will not interfere with the use of the land by landowner, or tenant.

In case where hard rock is encountered or as desired by CUGL/PMC/TPIA sand padding is to be provided up to height of 150 mm around the pipe.

When the trench has been dug through driveways or roads, all backfilling shall be executed with sand/ suitable material in layers as approved by Owner /Owner's representative and shall be thoroughly compacted. Special compaction methods as specified may be adopted. All costs incurred there upon shall be borne by the Contractor. Trenches excavated in dikes which are the properties of railways or which are parts of main roads shall be graded and backfilled in their original profile and condition. If necessary, new and/or special backfill materials shall be supplied and worked-up to.

PE Warning Grid/ Mat shall be placed on distribution main and service line inside premises, after backfill of the trench up to a height of 300mm on the top of the carrier pipes. The warning grid is to be unrolled centrally over the pipe section and thereafter further backfilling will commence.

Backfilling activity shall include proper compaction by jumping jack compactor, wherever required and as per instruction of CUGL/PMC/TPIA, and watering in layers of 150mm above the warning mat. Proper crowning of not more than 150mm shall be done. All the excavated material that could be used during the Restoration process shall be stacked and kept separately and properly. Wherever Road cutting/Tiles removal/PCC cutting has been done during excavation for laying, the area shall be back filled and compacted immediately so that no inconvenience is caused to the general public.

Electro-fusion of joints is to be undertaken immediately after lowering and the activity shall not be kept pending for lack of Electro-fusion jointing. The backfilling shall be considered complete only after the jointing of pipes.

Debris and other surplus material shall be removed immediately after the back filling.

The contractor shall not be entitled for payment as defined in commercial on laying and backfilling till the above activities are completed.

17.0 MOLING

The Manual Moling shall be carried out as per the requirement specified by Owner / Owner's representative and approved procedures. The contractor has to carry out survey of the underground utilities before going for the Moling to avoid any damage to other utilities. No extra payment will be made for any trial/abandoned pits made during the survey. The supply of all equipment required for carrying out moling work is in contractor's scope. The type of moling to be carried out i.e. with or without casing shall be at the discretion of Owner and prior approval is to be taken before starting the Moling.

For Moling the contractor shall ensure that the size of the hole shall not be more than 20% of the size of the casing/carrier pipes whichever is applicable. After completion of Moling the hole shall be properly compacted / filled with soil by watering and by approved procedures.

The moling rates are payable as per relevant SOR item and. The length of the Hole (excluding the sizes of the pits on both ends) shall be considered for the measurement of Moling length. However, the extra length of casing shall be considered for material consumption purpose only. In case of moling, where partial laying is carried out in casing and rest without casing, the relevant SOR i. Shall be applicable for both. Further, the payment for the pipeline laying in the excavated pits for Moling purpose will be made as per the SOR for normal laying.

Any damage occurred to other utilities during the moling operation shall be immediately, notified and rectified by the contractor without any cost implication to owner.

18.0 HORIZONTAL DIRECTIONAL DRILLING (HDD)

HDD is required to be carried out by the Contractor where conventional Trenching/Moling is not possible viz. Railways, major waterways, highways, roads, congested areas etc. The Contractor shall obtain details of such crossings and the Contractor in consultation with Owner shall prepare construction drawings. Execution of the work shall be based on the Owner / Owner's representative approved drawings. The contractor has to do the thorough survey of the underground utilities before commencement of HDD to avoid the damage to the other utilities. No other extra payment will be made for any trial/abandoned pits made during the survey. The supply of all equipment required for carrying out the HDD is in contractor's scope. The HDD operation shall be carried out in accordance with API-1102. The type and availability of machines is sole responsibility of the contractor and as per the site conditions & requirements to entire satisfaction of CUGL/PMC.

Once the work is allotted, any delay in mobilizing/ non-availability of HDD machines as per site requirement and conditions shall result in levying of penalties on daily basis as per SCC. However, in such cases, owner shall mobilize HDD machines and carry out execution of work on the contractor's risk and cost.

The type of HDD to be carried out with or without casing shall be at the discretion of Owner and prior approval is to be taken before starting the HDD.

The length of the Hole (excluding the sizes of the pits on both ends) shall be considered for the measurement of HDD length. The rates for HDD, as indicated in relevant SOR item i, as applicable on the site conditions, are payable as per the size of the carrier pipe and inclusive of excavation of pits, jointing, pilot boring, bentonite cleaning, reaming, insertion of carrier pipe, backfilling, compaction, etc.

As per the specification, HDD to be carried out with or without casing pipe depends on the type of crossing as per instruction of Owner/ Consultant.

Any damages occurred to other utilities during the HDD operation shall be immediately notified and rectified by the contractor without any cost implication to OWNER.

The measurement for the payment shall be measured as per the span for which the beacon/sensing source which is attached to the reamer at the time of pulling carrier pipe for HDD. HDD profiles should be properly marked in the as built drawing in scale before it is drafted in the as built drawing.

19.0 CASING PIPE

The tentative sizes of the HDPE casing pipe for Moling/ Horizontal Directional Drilling shall be as follows:

S. No.	MDPE Carrier Pipe Dia. size (mm)	Min. Dia. of HDPE Casing Pipe (mm)	Max. Dia. of HDPE Casing Pipe (mm)
1	32	50	90
2	63	125	160
3	125	200	250

However, the size of the casing pipe may vary according to the length of the carrier pipe and requirement of laying of HDPE duct & OFC cable, if required. Also, the higher size of HDPE casing pipe shall be preferred over lower size casing pipe without any extra cost to the Owner.

20.0 RESTORATION

Wherever the restoration to the original surface condition is in the scope of Owner or as directed by CUGL/PMC, all roads, footpaths (including roads and footpaths inside colonies) shall be restored to its original condition and the same shall be done as per CPWD/IRC norms and to the satisfaction of the concerned local Authority/Third Party Agencies designated by Owner. To retard curing of the installed concrete, wet sackcloth is to be placed on the finished surface and kept damp for a period of 7 days.

Where slabs and blocks are to be restored, the level of the compacted sub-base is to be adjusted according to the slab/block thickness. The slabs or blocks should be laid on moist bedding material, which should be graded sand, mortar or mortar mix. The slabs or blocks should be tapped into position to ensure they do not rock after lying.

The restored slabs or blocks should match the surrounding surface levels. Joint widths should match the existing conditions, and be filled with a dry or wet mix of mortar.

The procedure for restoration of Road/Footpath is just indicative. However, the restoration shall be done in accordance with the norms of the concerned Land owning agencies.

Turf shall be replaced in highly developed grassed area. In lesser-developed grassed areas top soil should be replaced during the restoration process.

Where permanent surface restoration cannot be completed immediately, the Contractor shall provide and maintain a suitable temporary running surface for vehicular traffic and pedestrians. The Contractor will be responsible for the maintenance of all restoration carried out, for the duration of the Contract guarantee period.

The Contractor is to ensure the restoration work is properly supervised and that the material used is suitable for the purpose and properly compacted. Where the required standards are not achieved, the Contractor will be required to restore the defective work.

Payment to the restoration shall be paid as per Relevant SOR item n. Further, the rate of restoration includes WBM, Asphalted /Bituminous, concrete pavement, Agra Stone/ Kota stone/ Tiles (Chequered / any other type of tiles), interlocking paver blocks, Dry brick pavements etc. and payable under one SOR.

Note that 90% payment for against restoration works shall be made after obtaining NOC from concerned land owing agency/RWA and remaining 10% upon closure of contract.

Contractor has to obtain the No Objection Certificate (NOC) from the concerned local authorities/RWA after completion of the restoration work. The restoration specification specified in the tender is only a typical specification and the contractor has to carry out restoration as per the latest version CPWD/IRC/MCD specification to its original condition and also to the entire satisfaction of landowner (Private/Public).

The expenditure incurred towards testing of the material used for restoration, as per the applicable standards, shall be borne by contractor.

21.0 TESTING

Pressure testing will be carried out with compressed air (free from oil and greases). Compressed air will be provided by Contractor for testing purposes and is to be included in the laying rates.

For both main and service pipeline laying, the Contractor shall perform progressive pressure testing to ensure no leaks in long lengths of pipe. The test pressure shall be 6.0 bar (g), and there shall be no unaccountable pressure loss during the test period.

Overall scheme drawing for pressure testing shall be prepared by the contractor and get approval from Owner/Owner representative.

For main line the test duration shall be 24 Hrs. with these tests, the pressure should be allowed to stabilize for a period of 30 minutes after pressurization. The holding period may then commence and continue for 24 hours. Measuring instruments shall have been calibrated and their accuracy and sensitivity confirmed before the start of testing, wherein, calibrated pressure gauges of suitable range shall be supplied by the contractor. The pressure gauges shall be calibrated from time to time as desired by CUGL/PMC. All testing shall be witnessed and approved by the CUGL or his delegated representative. Tie-in joints may be tested at working pressure following commissioning. In special cases, where the mainline and service line length is less than 500 mtrs, holding period for testing may be reduced to 4 hrs. with stabilization period of 15 minutes.

Testing for both main and service lines will be done in a single stroke, if PE Laying is completed up to service line tee from where tapping is taken. For service lines up to a length of 15 mtrs testing will be carried out independently of the testing of the mains (if service line is laid separately after commissioning of mainline) for which the test duration may be reduced to 30 minutes at 6 bar (g) pressure. The service line testing in this case will be performed after the service line installation is complete but before the service line tee has been tapped. Also in some cases the tapping of the service tee will be delayed pending the completion of testing and purging of the main pipelines.

22.0 PURGING

Purging shall be carried out in accordance with the principles defined in the American Gas Association publication "Purging Principles and Practice".

The Contractor shall also provide nitrogen required for purging as per the direction of Site In-charge. Nitrogen shall be supplied in labeled, tested and certified cylinders and

completed with all necessary regulators, hoses and connections, which will be in good and working condition. No separate payment shall be paid for supplying Nitrogen cylinders for purging and is included in the laying rates. Before purging cylinder should be checked for containing Nitrogen only.

In addition, the Contractor shall submit purging plan and get approval from Owner / Owner representative before commencing any purging work. The Plan shall include, but not be limited to the provision of the following materials and equipment:

Personal Safety Equipment,

Fire Extinguisher,

Purging Adaptor,

Purge stack with flame trap and gas sampling point,

Gas sampling equipment (may be gas leak detector),

Squash-off tool,

Polyethylene connecting pipe.

The Plan shall also include the purging process along with detail on the sequence of events. The process is to also specifically mention the need to lay a wet cloth over the PE main and in contact with the ground, to disperse static electricity during the purging work.

A purge stack with flame trap shall be used when purging services. Care shall be taken to ensure that the purge outlet is so located that vent gas cannot drift into buildings.

23.0 VALVE PITS/ CHAMBERS

Valve pits/ chambers (RCC/ Brick Wall/ Pre-cast RCC) shall be constructed as per enclosed relevant drawing in the tender document. Pre-fabricated valve chambers with same dimensions are also allowed however the final designing and specifications shall be approved by CUGL/ PMC before start of production, without any extra cost to owner.

If required, it may also be instructed for construction of new valve chambers on existing gas charged pipeline before or after Gas charging for extensions or new pipeline network.

Payment for the valve pit/ chamber construction shall be done as per relevant SOR. The construction of the valve chambers shall be taken up immediately after installation of valve, before commissioning of the pipeline network.

23.1 Material for Valve Pit

RCC Pre-cast Slab shall conform to IS: 456. Heavy Duty RCC Manhole Cover shall be used. It shall be with raised with Lifting hooks. The RCC manhole cover shall have a clear opening as per the Construction Drawings issued to the contractor.

23.2 Workmanship

The excavation work shall be done at a location given by Engineer-in-Charge. All care shall be taken not to damage existing facilities and surface of construction shall be restored to its original state.

Sand bags to be placed below pipeline without disturbing the laid pipe. Gunny bags and Sand should be of approved quality.

PCC to be placed below the pipe as indicated. Once PCC is set sand is to be filled and properly rammed so that pipe and pre-cast concrete blocks are firmly placed.

Valve will be supplied without the operating stem. Approved quality sand is to be placed in between area. The supply of sand is included in the rates.

Surrounding area to be properly cleared and PCC to be placed around the location where pre-cast slab with RCC Manhole cover is placed. The RCC pre-cast slab to be laid in level and finished smooth.

24.0 CONSTRUCTION OF TRENCHES AND OTHER SCOPE OF WORK IN BUILDER SEGMENT - NOT APPLICABLE

24.1 Construction of dedicated trench (as per approved drawing)

Trench Dimension- 0.6m x 0.66m x 1.0m (d x w x l)

Scope includes excavation of trench in any type of surface, construction of brick wall, waterproofing of trench (If required), removal of surplus malba, plastering of walls, watering and curing including supply & installation of precast RCC slab covers Sitecleaning and restoration of all damaged surfaces during construction activity. Contractor should submit NOC through concerned RWA/Builder/Authority. For other details please refer drawing

24.2 Construction of dedicated trench (as per approved drawing)

Trench Dimension- 0.375m x 0.66m x 1.0m (d x w x l)

Scope includes excavation of trench in any type of surface, construction of brick wall, waterproofing of trench(If required), removal of surplus malba, plastering of walls, watering and curing including supply & installation of precast RCC slab covers Sitecleaning and restoration of all damaged surfaces during construction activity. Contractor should submit NOC through concerned RWA/Builder/Authority. For other details please refer drawing attached in the tender.

24.3 Excavation of trench and installation of casing pipe by any method (Open cut /Moling)

Scope includes excavation of trench/ moling in any type of surface and installation of casing pipe casing pipe, restoration for road crossing inside society and obtaining NOC through concerned RWA/Builder/Authority.

24.4 Sand Filling in any type of trenches in builder segment only;

Scope includes supply and filling of coarse sand (Size 0.6 To 2.0mm) as per IS 383 free from impurity like clay, mica and soft flaky pieces in the trench as per instruction of EIC/Owners representatives.

25.0 PERMANENT ROUTE MARKERS

Permanent Route Markers (As per Drawings enclosed with the tender document) shall be fabricated, supplied and installed on the ROU at regular intervals as per the instructions of the CUGL/PMC immediately after laying of the Pipeline. The installation of the type of the Permanent Marker shall be decided by the CUGL/PMC depending on the site condition. The contractor shall also ensure that a sample of all type of markers shall be inspected and approved by Owner / Owner representative before shipment of the lot at site and prior to installation at the site. The inspection of all types of markers shall be carried out lot wise.

The RCC Route Markers shall be painted before installation as per the approved procedure. Whereas the Pole marker (Markers with foundation) and plate marker are to be supplied with powder coated Golden Yellow paint The supply of the paint as per

reference drawing and application. The supply of paint and application as per the specification is in contractor's scope. Payment shall be paid as per relevant SOR. Contractor shall obtain the approval lot wise & before installation at site from the Consultant / TPIA.

26.0 GUIDELINES FOR PERMANENT MARKER INSTALLATION:

- The installation of these markers shall be such that in between two pole markers two RCC route markers are installed with spacing of 50 mtrs on either side. However, Pole markers shall be installed at all the Tapping /Branching points in the mainline.
- Interval between any two RCC Route markers for mainline (125mm to 63mm) shall not be more than 50m.
- A Pole marker shall be installed near to valve chambers on Mainline & inside the pockets respectively for indication.
- Pole markers with foundations (As per the Drawings in Tender document) shall be installed after two RCC route markers.
- The entry and exit pits for laying of pipeline by HDD / Moling for Road crossings shall be marked by Pole markers or RCC Route markers depending upon the site conditions.

In addition to above, Pole markers with foundation (As per drawings in Tender document) shall be installed outside of individual societies/areas as per the instructions of the Owner representative.

- For the service distribution network 32mm & 20mm pipe, RCC route marker/ plate markers shall be installed as per the site conditions and directions of the Site-in- Charge.
- The artwork is typical for all the markers, with Owner's logo on it. The contractor must take prior approval for the artwork from CUGL/PMC before installation of Markers. The lot wise approval shall be attached with bills.

27.0 ASSISTANCE IN COMMISSIONING

Contractor shall provide the required personnel, Vehicles, labour, supervision, tools, equipment, instruments and technical assistance for performance tests and commissioning activities as per requirement / satisfaction of Owner /Owner's representative.

28.0 STANDARD OF WORK

All work carried out under this contract shall be to standards, codes of practice construction procedures and other technical requirements as defined in the technical specifications. The manpower deployed on the respective work shall be adequately trained and shall have necessary skills to execute/supervise the work. However, the assessment on the qualification of the personal shall be at the discretion of CUGL/PMC.

Fusion Operators and other skilled personnel like plumbers, conversion techniques shall be approved by Consultant/ Owner. Simultaneously Identification Cards duly signed by Consultant/ Owner shall be issued to them. The contractor shall maintain proper record for the identification cards issued to their workers.

29.0 RECORDING (AS-BUILT DRAWINGS)

The following points shall be taken care to the preparation of as built drawings.

- The as built drawings should be in the scale of 1:200 and shall be submitted in an A-0 sheet. The drawings shall be in layers according the AUTOCAD features category.

- Pipeline feature shall be shown as a continuous line, breaks only at joints, fittings, valves, tee point, etc. Diameter, Pipe material, length, and location of pipeline whether on the road or footpath, should be clearly indicated.
 - Minimum three (03) offsets of every joint, from permanent structure shall be recorded on As Built.
 - Distance of pipeline from permanent property/structure should be provided at least every 20 mtrs. If there is any change in alignment / orientation and offset distances etc. Of the pipeline in between the above said 20 mtrs, the same shall be clearly mentioned in the as laid. Gas objects (off valves, tees, elbows, couplers, transition fittings etc.,) shall be shown as block objects (which form a single node to connect) with respect to Owner symbols / legend. The As laid drawings shall be as per the approved legends provided by CUGL/PMC.
 - Details & offset distances from other utilities present (e.g. MTNL, NDPL, BSES, DJB etc.) should be given in as laid drawing. If there is any change in depth of the pipeline, the same shall be clearly marked with details in the as laid drawings. The details (material, size & Length) of additional protection provided to pipeline shall also be clearly indicated.
 - Details of the PE stop off valves & Other fittings used (i.e. tees, elbows, couplers, transition fittings, etc.) should be shown with adequate information orientation & Offsets from permanent structures in the immediate vicinity.
 - Technical deviations (if any) should be provided with reference to the buildings permanent structures around, and the same should be cited clearly with all the relevant details, including separate sketches/Blowups / sectioned drawings / exploded view.
 - Total as laid-length (size wise), bill of materials should be mentioned in each sheet.
 - Complete details of nallah crossings should be shown in a separate sketch.
 - Names of roads, major landmarks and buildings should be mentioned appropriately for reference.
 - Proper chainage shall be mentioned on all the drawings to be referred with continuation reference.
 - Direction of gas flow shall be indicated in each of the drawings.
 - Text on the as laid drawing should be clearly visible.
 - Land base features shown on the drawing shall match the exact distance as they were on real ground with respect to scale (1:200).
 - As built drawings shall be duly signed & stamped by area TPIA / Consultant.
 - The details shall be prepared in standard format using MAP INFO/AUTOCAD MAP and submitted CD RAM. Contractor shall also make the item wise material consumption report for the respective areas in a soft copy and to be submitted along with the as-
-

built drawings.

30.0 CIVIL WORKS

The contractor has to supply the adequate materials and skilled manpower for the completion of all the civil works. The contractor shall also ensure that the work is carried out as per the details mentioned in the Schedule of rates.

Special cares shall be taken at the time of labours working in depths/ lifting of the skids by hydras/ cranes considering all the safety guidelines.

The contractor has to ensure that sample of the all the materials shall be inspected and approved by CUGL/PMC before carrying out installation or erection work. The contractor has to submit the test certificates for all the materials to be used at the site. The construction shall be carried out strictly as per the drawings provided by the CUGL/ Consultant. The contractor shall ensure extra / surplus materials / malba shall be immediately removed from the site after completion of the job.

31.0 GIS MONITORING

GIS is an integrated set of hardware and software tools which is used to update and manage the digital spatial (geographic) and related attribute data. GIS solution provides the standard, central applications for engineering, operations, and asset management and is mandated by PNGRB. Contractor has to collect the data as per the format attached.

S no	FeatureClassName	Required Field collected From Survey	Remarks
1	Network Valve(PE valve)	GPS and Location Description	
		Set_Pressure	
		Valve Material	
		Bonded Indicator	
		Ground Level Indicator	
		Insulated Indicator	
		Manufacturer	
		Valve Function	
		Gas Valve Manufacturing Specification	
		Gas Valve Body Material	
		Valve Size	
		Maximum Operating Pressure	
		Maximum Allowable Operating Pressure	
2	Distribution Point	Location	
		Building_ID	
		RegulatorStationID	
		Connection Type	

		DP_ID	
		Subtype(Cust-Type)	
		Guard-Type	
		Premise	
		Owner	
3	GasFittings	Fitting Diameter	
		Material	
		Fitting Type	
		Fitting End	
		Fitting Orientation	
		Protection Type	
		Ground Status	
		Owner	
		Manufacturer	
4	DistributionMain	Nominal Diameter	
		Nominal Diameter units	
		Design Pressure-Unit of measure	
		LineDepth	
		Operating Pressure	
		Coating Type	
		Status of pipe	
		Outside Diameter	
		GasPipe Type	
		Pipe Testing Type	
		Surface_Type	
		Pipe Ground Status	

- Note** GPS coordinate of joints of MDPE, each fittings and valves to be submitted.
GPS coordinated of bends and tappings to be submitted.
GPS Coordinate of Route Marker (RCC & Pole) along with direction of gas flow to be submitted

ANNEXURE # 1

TOOLS & EQUIPMENTS TO BE PROVIDED BY THE CONTRACTOR FOR PE LAYING

Sl.	Equipment Details	Indicative Requirement (in Nos.)
1	Automated Electro Fusion Machine	2
2	Voltage Stabilizer	2
3	Generator (5.5 KVA)	2
4	Moling Equipment (for all sizes)	As and when required
5	HDD Machines & Equipment (for all types & sizes)	As and when required
6	Squeeze Tools (Manual) up to 63 mm. certified as per GIS/PL2 part 7 by TPIA accredited to NABCB and approved by CUGL/PMC	4
7	Squeeze Tools (Hydraulic) from 63 mm up to 180 mm. certified as per GIS/PL2 part 7 by third part inspection agency accredited to NABCB and approved by CUGL/PMC	4
8	Rotary Peelers	2
9	Hand Scraper (Aluminium Handle with blade) certified as per GIS/PL2 part 5 by TPIA accredited to NABCB and approved by CUGL/PMC	3
10	Top loading Tapping Tools/Allen Keys certified as per GIS/PL2 part 5 by TPIA accredited to NABCB and approved by CUGL/PMC	Three sets of all sizes
11	Pipe Cutter (Guillotine) as per GIS/PL2 part 5 by TPIA accredited to NABCB and approved by CUGL/PMC	5
12	Test Ends for pressure test as per GIS/PL2 part 5 by TPIA accredited to NABCB and approved by CUGL/PMC	One set of all sizes
13	Gas Detection Unit	As and when required
14	Cable and Pipe Locator	As and when required
15	Pipe Alignment Clamps (32 - 90 mm) as per GIS/PL2 part 5 by TPIA accredited to NABCB and approved by CUGL/PMC	3
16	Pipe Alignment Clamps (90 - 180 mm) as per GIS/PL2 part 5 by TPIA accredited to NABCB and approved by CUGL/PMC	3
17	Pipe Straightener	2
18	Re-rounding Tools as per GIS/PL2 part 5 by TPIA accredited to NABCB and approved by CUGL/PMC (All Sizes)	2

FOR LAYING OF POLYETHYLENE MAIN AND SERVICE PIPELINE
FOR PNG DOMESTIC CONNECTIONSDOC NO: VPC-SS-PE-0001
Rev No : 00

19	Jumping Jack Compactor	As and when required
20	Roller for Asphaltting	As and when required
21	Calibrated Pressure Gauges (0-10 Bar)*	10
22	Water Tankers	As and when required
23	Heating Element for HDPE Butt Joint along with clamping, roller and other accessories.	As and when required

Note: Pressure Gauges (0-10 Bar) shall be calibrated at every Six months. Approval Certificate of all tools to be submitted by contractor.

ANNEXURE # 2

FUSION COUPLERS FROM 20MM TO 125MM

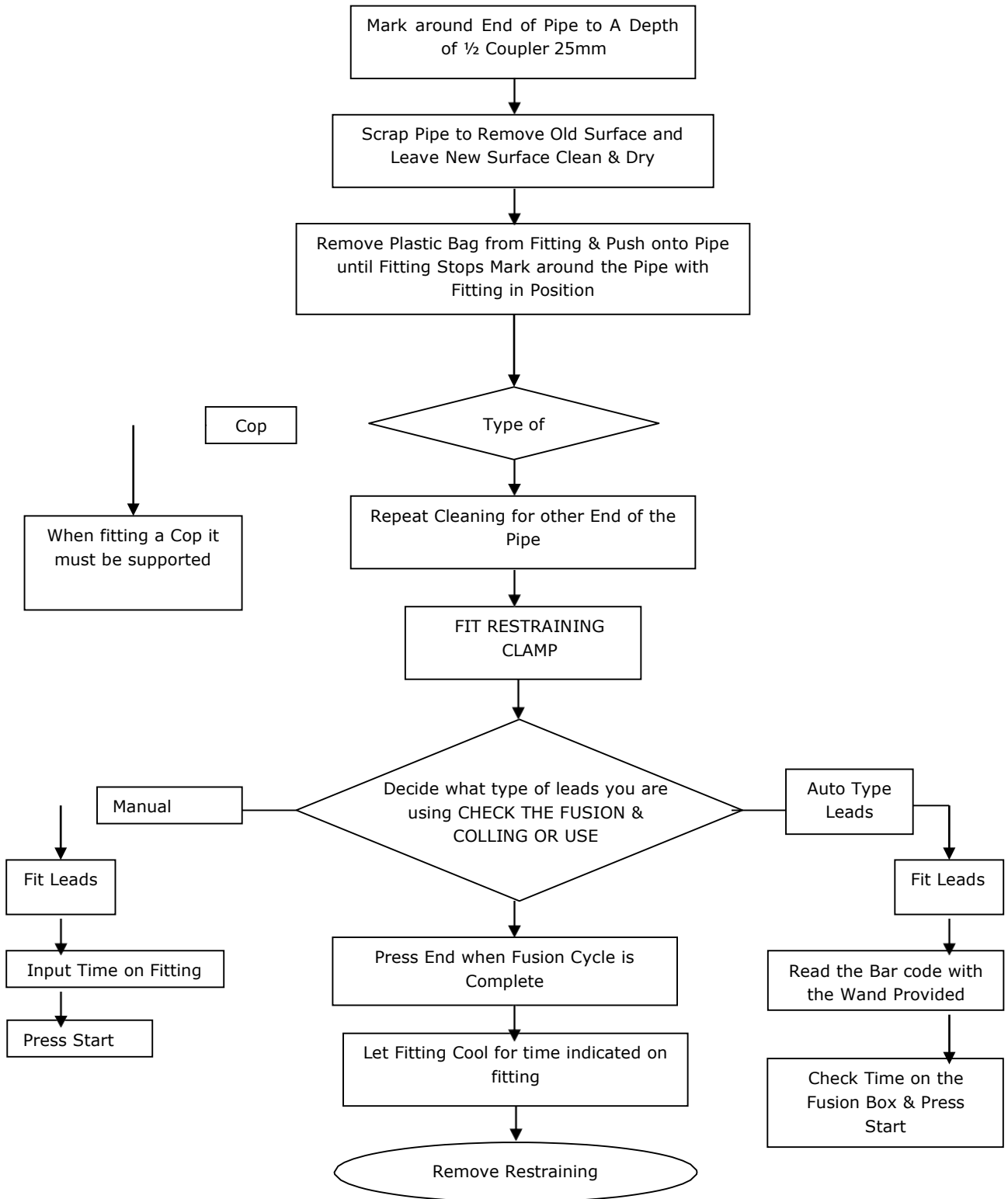

ANNEXURE # 3

RESTORATION PROCEDURE/GUIDELINES FOR ROAD CUTS OF MCD AND OTHER LANDOWNING AGENCIES

1. PURPOSE AND OBJECTIVE

The main purpose and objective of this document is to ensure that all the work are carried out with proper specifications and standards with high quality and timely accomplishment, and the restoration of infrastructure is according to standards Aimed at achieving the original condition of the road infrastructure.

2. DOCUMENTS/FILES TO BE MAINTAINED:

The following documents shall be maintained during execution of the job and shall be handed over to OWNER/Consultant/TPI after completion of the job;

- Copy of permission letter obtained from MCD.
- Drawing/Sketch showing the details of stretch to be cut, highlighting the type of surfaces and its chainage/length (area)
- Stage wise Photographs of the stretch.
- Test Certificates of the Construction materials to be used.
- Routine Test Certificates for construction materials during progress of job.

32.0 RESTORATION OF TRENCHES/PITS:

After laying pipeline, backfill material without containing extraneous material or hard lumps of soil or stones shall be filled and watered in layers of 150mm. Warning mats shall be placed as per specification. Earth shall be filled watered and compacted in layers with the help of earth compactor (Jumping jack compactor where ever space is available).After backfilling, the crown of the earth shall be between 50mm and 100mm above road surface and shall be free from sharp-edge stone and boulders.

After consolidation of backfill, the surplus earth shall be removed and disposed at place directed by OWNER (at suitable locations, as per direction of MCD)

Further, depending upon the Surface types of following specification shall be adopted:

**FOR LAYING OF POLYETHYLENE MAIN AND SERVICE PIPELINE
FOR PNG DOMESTIC CONNECTIONS**

**DOC NO: VPC-SS-PE-0001
Rev No : 00**

Sl. No.	Surface Types	Specification Recommended
1	Cement Concrete Surface	Top Surface – PCC 1:2:4, 100 mm Thick Compacted with Plate Vibrator shall be laid over base course. Base Course – PCC 1:5:10, 75 mm Thick laid over compacted backfilled earth.
2	Brick Soiling	Top Surface – Brick Soiling (as per original type) shall be laid over base course. Base Course – PCC 1:5:10, 75 mm Thick laid over compacted backfilled earth.
3	Interlocking CC Paver Block	Top Surface – Interlocking CC Paver Blocks (as per original type) shall be laid over compacted fine sand 50 mm Thick over base course. Base Course – PCC 1:5:10, 75 mm Thick laid over compacted backfilled earth.
4	Chequered Cement Concrete Tiles/Pre-cast CC Tiles/Kota Stone Floor/Red Stone Floor	Top Surface – Tiles/Floor (as per original type) shall be laid over Cement Sand Mortar 1:6, 20mm Thick over base course, Joints shall be pointed/finished to match colour. Base Course – PCC 1:5:10, 75 mm Thick laid over compacted backfilled earth.
5	Bituminous Surface (for Category D Roads i.e.; Roads less than 13.70 Mwidth)	Top Surface – 40mm Thick Bituminous Concrete (as per original type) shall be laid over PCC 1:2:4, 100 mm Thick over base course. Base Course – PCC 1:5:10, 75 mm Thick laid over compacted backfilled earth.
6	Bituminous Surface (for Category C Roads i.e.; Roads less than 18 M width but greater than 13.70 M width.)	Top Surface – 40mm Thick Bituminous Concrete (as per original type) shall be laid over PCC 1:2:4, 150mm Thick over base course. Base Course – PCC 1:5:10, 150 mm Thick laid over compacted backfilled earth.

The specification mentioned above may be modified in line with relevant MCD/CPWD/IRC specifications. Contractor has to follow the changes as informed to them time and again.

NOTE:

Wherever the Bituminous portion is cut in small patches or isolated location where area of Bituminous portion is very less due to constraints like other utilities, the surface shall be restored, same as specified for the cement concrete surface, with prior approval of CUGL/PMC/TPI.

33.0 TESTING OF CONSTRUCTION MATERIALS

For the different construction materials proposed to be used the following tests are required to be carried out for approval:

Sl.No.	Material	Test	Method of Testing	Frequency of Test
1	Cement	Setting time, soundness, compressive strength and fineness	As per IS: 4031	Once for each consignment or as and when required/directed
2	Bricks	Compressive strength, water absorption and efflorescence	As per IS: 3495	Minimum five samples or as per IS: 5454
3	Coarse Aggregates	Sieve analysis, flakiness index, estimation of deleterious materials, organic impurities, moisture contents and specific gravity	As per IS: 2386	One test per source of supply and routine test regularly as directed
4	Fine Aggregates	Sieve analysis, clay silt and moisture contents and specific gravity	As per IS: 2386	One test per source of supply and routine test regularly as directed

In addition to the above construction materials such as inter locking paver blocks, chequered cement concrete tiles, Pre-cast CC tiles, Kota/Red Stones Flooring samples shall be arranged for approval before use and if required testing shall be arranged.

For Cement concrete works the minimum frequency of sampling of concrete (CC cubes) shall be as follows:

Sl. No.	Quantity of concrete in Cu. M	No. of Samples
1	1 - 5	1
2	6 - 15	2
3	16 - 30	3
4	31 - 50	4
5	51 and above	4 + 1 additional sample for each additional 50 Cu. M and part thereof.

The cement concrete cubes shall be tested for 7 & 28 days as per relevant IS code.

33.0 INSPECTION BY THIRD PARTY INSPECTION (TPI) AGENCIES NOMINATED BY LAND OWNING AGENCIES

It is the responsibility of the contractor to give inspection call, at least one week in advance to OWNER, to arrange for inspection by TPI nominated by land owning agencies along with the file containing all relevant documents mentioned in Clause 2 of Annexure 3 Before inspection by TPI nominated by land owning agencies, contractor has to arrange for the inspection of the restored area by OWNER/Consultant/TPI and get the work certified. Contractor has to arrange for all necessary equipment, tools & tackles, labour for carrying out the inspection of the restored area. It is the responsibility of the contractor to obtain "No Objection Certificate" (NOC) from the TPI nominated by the land-owning agencies and further NOC from Land Owning Agencies and to get the securities/ Bank Guarantees paid to them, for obtaining the permissions.



**SS-MEDIUM DENSITY
POLYETHYLENE FITTINGS**

VPC-SS-PE-0026

**STANDARD SPECIFICATION FOR MEDIUM DENSITY
POLYETHYLENE FITTINGS**



**SS-MEDIUM DENSITY
POLYETHYLENE FITTINGS**

VPC-SS-PE-0026

TABLE OF CONTENTS

1.0	SCOPE.....	3
2.0	APPLICABLE CODES, SPECIFICATIONS AND STANDARDS.....	3
3.0	ABBREVIATIONS & TERMINOLOGY	4
4.0	TECHNICAL REQUIREMENTS.....	4
5.0	MATERIALS	7
6.0	DESIGN.....	8
7.0	DIMENSIONS AND TOLERANCES.....	11
8.0	DOCUMENT REQUIREMENT.....	15
9.0	QUALITY ASSURANCE PLAN	15
10.0	MARKING.....	16
11.0	PACKAGING	16



SS-MEDIUM DENSITY POLYETHYLENE FITTINGS

VPC-SS-PE-0026

1.0 SCOPE

This specification along with applicable codes and standards describes the minimum requirements for design, selection, manufacture, inspection/ testing and supply of "MDPE FITTINGS".

This specification elaborates the requirements for Electrofusion fittings in the nominal size range 16 mm to 180 mm made from PE compound used with PE pipes for supply of natural gas and to be used at operating pressure 4.0 bar(g) & operating temperature 25°C.

The material grades shall be PE100 and SDR 11.

2.0 APPLICABLE CODES, SPECIFICATIONS AND STANDARDS

EN 1555-1: Plastics piping systems for the supply of gaseous fuels- Polyethylene (PE) - part 1: General

EN 1555-2 / ISO 4437-2 / IS-14885: Plastics piping systems for the supply of gaseous fuels- Polyethylene (PE)

EN 1555-3: Plastics piping systems for the supply of gaseous fuels- Polyethylene (PE) - part 3: Fittings

EN 1555-5, Plastics piping systems for the supply of gaseous fuels -Polyethylene (PE)- Part 5: Fitness for purpose of the system

EN 1555-7: Plastics piping systems for the supply of gaseous fuels- Polyethylene (PE) - part 7: Guidance for assessment of conformity

EN 1716, Plastics piping systems — Polyethylene (PE) tapping tees — Test method for impact resistance of an assembled tapping tee

ISO TR 13950:1997 or latest edition: Plastics pipes and fittings - Automatic recognition systems for Electro fusions

ISO/IEC 16390:1999 or latest edition: Information technology – Automatic identification and data capture techniques – Bar code symbology specification- Interleaved 2 of 5

EN ISO 17778, Plastics piping systems — Fittings, valves and ancillaries' — Determination of gaseous flow rate/pressure drop relationships

EN ISO 1133, Plastics — Determination of the melt mass-flow rate (MFR) and the melt volume-flow rate (MVR) of thermoplastics

EN ISO 3126, Plastics piping systems — Plastics piping components — Measurement and determination of dimensions

ISO 228-1, Pipe threads where pressure-tight joints are not made on the threads – Part 1: Dimensions, tolerances and designation

PNGRB and other referrals in the above applicable codes.

3.0 ABBREVIATIONS & TERMINOLOGY_{d_n}

d_o : Nominal Outside Diameter

e_n : Nominal Wall Thickness

SDR : Standard Dimension Ratio = d_n / e_n

LTHS : Long Term Hydrostatic Strength (at 20°C for 50yrs)

LCL : Lower Confidence Limit – Stress value (MPa) of mean LTHS

MRS : Minimum Required Strength – min. value (in MPa) for LTHS of material

C : Design Co-efficient – As per ISO: 12162 Table-2

σ_s : Design Stress (= MRS/C)

MFR : Melt Mass Flow rate – Value related to viscosity of the molten material at a specified temp. and rate of shear. (expressed in g/10min.)

D_f : De-rating Co-efficient (Refer Table A.1, Annex A – EN 1555-5)

MOP : Maximum Operating Pressure = $(20 \times MRS) / \{(SDR-1) \times C \times D_f\}$

EF : Electrofusion

4.0 TECHNICAL REQUIREMENTS

The design of fittings shall be as per European Standards EN 1555-3 and the complementary particular requirement.

The fittings are intended to be use in gas distribution networks made of PE and Steel/GI pipes.

No component of the fitting shall show any signs of damage, scratches, pitting, bubbles, blisters, inclusions or cracks to an extent that would prevent conformity of the fittings to the requirements of this standard.

Color of the PE parts of fittings shall be black as per PNGRB.

Allowable pressure drop shall be as per the standard ISO 17778.

Any melt exudation shall not cause wire movement in electrofusion fittings such that it leads to short-circuiting, when jointed in accordance with the manufacturer's instructions. There shall be no excessive creasing of the internal surfaces of the adjoining pipes.

Fittings joints shall conform to EN 1555-5 and shall be leak proof.

Electrical characteristics

- a. For voltages greater than 25 V, direct human contact with energized parts shall not be possible when the fitting is in the fusion cycle during assembly in accordance with the instructions of the manufacturers of the fittings and of the assembly equipment, as applicable.
- b. The manufacturer shall state the tolerance on the electrical resistance of the fitting at 23 °C. The resistance shall not exceed the following value: [nom. value \pm 10 %] + 0.1 Ω .
- c. Note: 0.1 Ω is the assumed value of the contact resistance.
- d. The operating voltage of the fittings shall remain 40 +_ 0.5 V.
- e. The surface finish of the terminal pins shall allow a minimum contact resistance in order to satisfy the resistance tolerance requirements. Electrofusion terminal connections shall be as per Annex A of EN 1555-3.

Mechanical characteristics

- a. Fittings shall have mechanical characteristics conforming to the requirements given in Table 4 of standard EN 1555-3.
- b. The technical descriptions of the manufacturer shall include the following information:
 - a) field of application:
 - pipe and fitting temperature limits;
 - pipe series or SDRs;
 - ovality;
 - b) assembly instructions;
 - c) fusion instructions:
 - fusion parameters with limits;

d) data for saddles and tapping tees:

- the means of attachment (tools and/or under clamp);
 - Need to maintain the under clamp in position in order to ensure the performances of the assembly.
- c. Unless otherwise specified by the applicable test method, the test pieces shall be conditioned at (23 ± 2) °C before testing.
- d. Testing of fitting shall be in accordance with the test methods as specified in Table 4 of standard EN 1555-3 using the indicated parameters.
- e. Hydrostatic test pressure and minimum test period shall be as per Table-5 of EN 1555-3.

Physical characteristics

- a. Fittings shall have physical characteristics conforming to the requirements given in Table 7 of standard EN 1555-3.
- b. Thermal stability test shall be done at 200 deg. C by means of differential scanning calorimetry (DSC), considering oxygen induction time (OIT) ≥ 20 min.
- c. Melt mass flow rate shall be calculated at 190 deg. C by applying 5 Kg of load on test specimen. It shall be expressed in g/ 10min.
- d. Unless otherwise specified by the applicable test method, the test pieces shall be conditioned at (23 ± 2) °C before testing.
- e. Testing of fitting shall be in accordance with the test methods as specified in Table 7 of standard EN 1555-3 using the indicated parameters.

Performance requirements

When fittings are assembled to each other or to components conforming to other parts of EN 1555, the joints shall conform to EN 1555-5.

In case of wall thickness design different from that according to Table-2 of EN 1555-3, fittings and associated joints shall additionally meet the performance requirement listed in Table-6, EN 1555-3.

Electro Fusion Fitting Jointing

- a) For Electro Fusion fitting jointing an electrical resistance element is incorporated in the socket of fitting which when connected to an appropriate power supply, melts and fuses the materials of the pipe and fitting together.

- b) The effectiveness of this technique depends on attention to the preparation of the jointing surfaces, in particular the removal of the oxidized surface of the pipe over the socket depth and ensuring the jointing surface are clean. If ovality causes gap between concentrically located pipe and the fitting to exceed 1% of the pipe OD after re-rounding to ensure correct welding. If the gap still exceeds 1% of the pipe OD after re-rounding then a check should be made of the pipe OD dimensions to determine if it meets specification.
- c) The maximum gap between eccentrically located pipe and fitting i.e. pipe touching fitting at one point must not exceed 2% of the pipe OD.
- d) Sometimes coiled pipes may be too oval to fit into couplers, or the end of the pipe may make the alignment of the ends impossible. In such circumstances the use of a mechanical pipe straightener or rounding tool is necessary.

Electro-Fusion Saddle Jointing

- a) For Electro Fusion fitting jointing an electrical resistance element is incorporated in the socket of fitting which when connected to an appropriate power supply, melts and fuses the materials of the pipe and fitting together.
- b) The effectiveness of this technique depends on attention to the preparation of the jointing surfaces, in particular the removal of the oxidized surface of the pipe over the socket depth and ensuring the jointing surface are clean.
- c) Method of holding the tapping tee saddle during the fusion cycle are used namely top loading and under clamping space around the pipe. In a trench a minimum clearance of 150 mm is required.

Conditioning Period

Refer below table (Table-1 of ISO 11413) for minimum conditioning required for joints.

Nominal wall thickness, e_n Mm	Minimum conditioning period H
$e_n < 3$	1
$3 \leq e_n < 8$	3
$8 \leq e_n < 16$	6
$16 \leq e_n < 32$	10
$32 \leq e_n$	16

5.0 MATERIALS

- 5.1** The PE compound from which the fittings with electrofusion socket are made shall conform to EN 1555-1.

**SS-MEDIUM DENSITY
POLYETHYLENE FITTINGS**

VPC-SS-PE-0026

- 5.2** The PE compound of the fittings shall be made only from virgin material conforming to EN 1555-1. PE compound shall be cadmium free pigment compound.
- 5.3** All parts of the fittings in contact with the gas stream shall be resistant to the gas, its condensates and other occurring substances such as dust.
- 5.4** The PE fittings made from below listed material are forbidden:
- a) Use of recycled materials
 - b) Mixture of different materials
 - c) Addition of complementary materials
- 5.5** The material and constituent elements used in marking of fittings (including elastomers, greases and any metallic part, if used) shall be resistant to the external and internal corrosion and shall have life expectancy under following conditions atleast equal to the PE pipes with which they are intended to be used.
- a) During storage
 - b) Under the effect of the gas conveyed
 - c) With respect to the services environment and operating conditions
 - d) Fittings material in contact with the PE pipe shall not adversely affect pipe performance or initiate stress cracking.
- 5.6** All metal parts susceptible to corrosion shall be adequately protected.
- 5.7** When dissimilar metallic materials are used which can be in contact with moisture, steps shall be taken to avoid the possibility of galvanic corrosion.
- 5.8** Greases or lubricants shall not exude onto fusion areas, and shall not affect the long-term performance of fitting materials. Other materials conforming to 4.2.1 of EN 1555-3 may be used provided that it is proven that the fittings conform to this standard.

6.0 DESIGN

Fittings shall be designed for system operation at the pressures given in below table.

Material	M.R.S. MPa	LCL (20°C, 50Yrs 97.5%) MPa	Maximum Allowable Operating Pressure	Operating Voltage
PE 100	10.0	$10.00 \leq \text{LCL} \leq 11.19$	7.0 bar	40 +_ 0.5V

Fittings shall be free from cracks, voids, blisters, distortion, dent or other defects.

Fittings shall be capable of being fusion jointed to pipes using control boxes. The fittings shall exhibit the strengths and fusion compatibility with pipes of respective sizes.

Each fitting shall be bar coded which shall conform to ISO/TR 13950:1997 & ISO/IEC 16390:1999 or latest edition's and shall have a permanent fusion indicator.

Heating coil design shall be such that it should not be damaged during assembly leading to short circuit of heating coil.

6.1 Electrofusion Jointing:

PE pipes, fittings and valves intended to be used for jointing by electrofusion shall be prepared and assembled in accordance with ISO 11413. The conditions for the preparation of the joints are given in clause 4.2.3 of EN 1555-5 for the assessment of fitness for purpose of electrofusion joints.

For joints with electrofusion saddle fittings, the electrofusion saddle fitting shall be fused to the pipe, while it is pneumatically pressurized to the allowable maximum operating pressure. The pipe shall be cut immediately after the manufacturer prescribed cooling time has elapsed.

These joints with electrofusion saddle fitting should be prepared taking into consideration national safety regulations.

For straight equal electrofusion socket fittings (couplers) test joints on selected diameters out of the product range shall be prepared with a gap of $0.05d_n$ between the pipe end and the maximum theoretical depth of penetration of the fitting, wherefor diameters greater than 225 mm the adjoining pipes shall be arranged to provide the maximum angular deflection possible for the fitting, limited to 1.5° .

6.2 Electrofusion Socket Fittings

Electrofusion Socket Fittings shall incorporate a method of controlling pipe penetration within each socket. The inner cold zone of each socket shall not be less than $(0.1 d + 5)$ mm for sizes upto 125 mm & $0.1 d$ for sizes greater than 125 mm.

Depth of penetration (L1) and Fusion zone length (L2) shall be as per figure-1 & Table-1 (Clause 7.1) of SS.

- a) Elbow/Bends: Both ends of Elbow/Bends shall be electrofusion type with integral stop.
- b) Coupler: Both ends of coupler shall be electrofusion type with integral stop.
- c) Reducer: Reducer ends shall be electrofusion type with integral stop.
- d) Cap: Caps shall be electrofusion end type for leak proof termination of line.
- e) Equal Tee: Main/Header ends of tee shall be electrofusion type. Branch end shall be plain.

6.3 Tapping Tees & Saddles

Tapping Tees and Saddle shall be Wrap Around type for branch connection for ensuring proper alignment and better fusion process.

**SS-MEDIUM DENSITY
POLYETHYLENE FITTINGS**

VPC-SS-PE-0026

The tapping tees shall provide a means of cutting through the pressurized main pipe and allowing the gas flow into the outlet pipe. Internal cutter shall be of SS material.

Branch End shall be plain.

Dimensions H, H1, H2 and L shown in figure 2 of SS shall be as per manufacturer standard.

6.4 Transition Fittings

Transition fitting shall be seal tight, pull out resistant and have greater tensile value than that of PE part.

Ends for transition fittings other than electrofusion shall be as per below requirement:

Table – A1

Transition	Size	PE End	Steel / GI End Connection	Min. Length (mm) End to End	Min. Req'd. Steel Length for BE
PE to SS	20mm x 1/2"	EF	Threaded End	80	-
PE to GI	32mm x 3/4"	EF	Threaded End	80	-
PE to CS	32mm x 1"	EF	Threaded End	80	-
PE to CS	63mm x 2"	Plain End	Bevel End	470	400
PE to CS	125mm x 4"	Plain End	Bevel End	570	480
PE to CS	180mm x 6"	Plain End	Bevel End	590	485

6.5 PE Pipes to Bevel Ends

To make connection between steel pipe and MDPE pipe, specially fabricated transition pieces consisting of Steel and MDPE pipes should conform to the following requirements:

- a) MDPE pipe with one end plain should conform to the specification (EN 1555-2 / ISO 4437-2 / IS-14885/ SDR 11).
- b) MDPE end shall be compatible (thickness/ nominal size) to the interconnecting PE pipes of the network.
- c) Steel end (CS/SS) shall be compatible (grade of material/ thickness/ nominal size) to the interconnecting steel pipes of the network.
- d) Steel end of the fitting should be beveled for welding. Angle of bevel should be 30° + 5°.
- e) Steel and MDPE pipes should be so jointed in the factory so as to have a monolithic joint which is leak free and should be mechanically as strong as or stronger than the PE Pipe.

- f) Minimum required length of steel for transition fitting is specified in Table A1. Vendor to provide adequate length so that the PE part of the fitting / pipe will not get effected during welding at site.
- g) Joint between metallic and non-metallic part of transition fitting shall be leak- proof.

6.6 PE Pipes to Threaded Ends

- a) Transition fitting for jointing of MDPE Pipes conforming to specification SDR 11, IS: 14855/ ISO: 4437/ EN1555-2.
- b) The transition fittings shall be electrofusion type for PE connection, NPT Female threading conforming to ANSI B 1.20.1.
- c) Steel end (CS/SS) / GI shall be compatible (grade of material/ thickness/ nominal size) to the interconnecting pipes of the network.
- d) Joint between metallic and non-metallic part of transition fitting shall be leak- proof.

7.0 DIMENSIONS AND TOLERANCES

Dimensions shall be measured in accordance with EN ISO 3126 at (23 ± 2) °C, after being conditioned for atleast 4 h. The measurement shall not be made less than 24 h after manufacture.

7.1 For Electro Fusion Socket Fittings

For electrofusion sockets (see Figure 1) having a nominal diameter given in Table-1, the socket diameter and lengths shall be given by the manufacturer and shall conform to Table 1 with the following conditions:

- a) $L_3 \geq 5 \text{ mm}$;
- b) $D_2 \geq d_n - 2e_{\min}$

Where,

e_{\min} is the minimum wall thickness specified for the corresponding pipe conforming to EN 1555-2;

D_1 is the mean inside diameter in the fusion zone measured in a plane parallel to the plane of the mouth at a distance of $L_3 + 0.5L_2$ from that face;

D2 is the bore, which is the minimum diameter of the flow channel through the body of the fitting;

L1 is the depth of penetration of the pipe or male end of a spigot fitting. In case of a coupling without stop, it is not greater than half the total length of the fitting;

L2 is the heated length within a socket as declared by the manufacturer to be the nominal length of the fusion zone;

L3 is the distance between the mouth of the fitting and the start of the fusion zone as declared by the manufacturer to be the nominal unheated entrance length of the fitting.

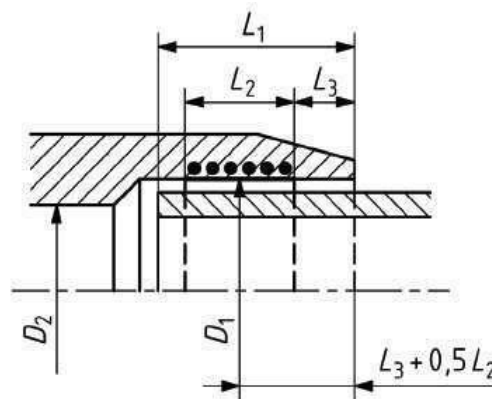

Figure 1 — Dimensions of electrofusion socket fittings

The mean inside diameter of the fitting in the middle of the fusion zone (see L1 in Figure 1) shall be not less than d_n .

Table - 1

Nominal Diameter r d_n (mm)	Depth of Penetration L_1 , min.			Fusion Zone L_2 , min.
	Intensity Regulation L_1 , max.	Voltage Regulation		
16	20	25	41	10
20	20	25	41	10
25	20	25	41	10
32	20	25	44	10
40	20	25	49	10
50	20	28	55	10
63	23	31	63	11
75	25	35	70	12
90	20	25	41	10
110	32	53	82	15

**SS-MEDIUM DENSITY
POLYETHYLENE FITTINGS**

VPC-SS-PE-0026

125	35	58	87	16
140	38	62	92	18
160	42	68	98	20
180	46	74	105	21

The manufacturer shall declare the actual minimum and maximum values of D1 to allow the end-user to determine their suitability for clamping and joint assembly and fitness for purpose testing in accordance with EN 1555-5.

In the case of a fitting having sockets of differing nominal diameters, each one shall conform to the requirements for the nominal diameter of the corresponding component.

7.2 Wall Thicknesses

In order to prevent stress concentrations, any changes in wall thickness of the fitting body shall be gradual.

- a) The wall thickness of the body of the fitting at any point, E , shall be greater than or equal to e_{min} for the corresponding pipe at any part of the fitting located at a distance beyond a maximum of $2L_1/3$ from all entrance faces if the fitting and the corresponding pipe are made from a polyethylene having the same MRS.

If the fitting is produced from a polyethylene having an MRS that is different from that of the corresponding pipe, the relationship between the wall thickness of the fitting, E , and the pipe, e_{min} , shall be in accordance with Table 2.

Table 2 — Relation between fitting and pipe wall thicknesses

Pipe and fitting material		Relation between fitting wall thickness, E , and pipe wall thickness, e_n
Pipe	Fitting	
PE 80	PE 100	$E \geq 0,8e_n$
PE 100	PE 80	$E \geq e_n/0,8$

- b) In the case of a wall thickness design different from that according to a), fittings and associated fusion joints shall additionally meet the performance requirement given in Table6 of EN 1555-3.
- c) When a fitting leaves the site of the manufacturer, the out-of-roundness of the bore of a fitting at any point shall not exceed $0.015dn$.
- d) The dimensional characteristics appropriate to each manufacturer such as the overall dimensions or mounting dimensions shall be specified in a technical file.

7.3 For Electro Fusion Saddle Tapping Fittings

Outlets from tapping tees and branch saddles shall have an electrofusion socket conforming to Clause 7.1 of SS.

The manufacturer shall specify the overall dimensions of the fitting in a technical file. These dimensions shall include the maximum height of the saddle, H , and for tapping tees the height of the service pipe, H_1 or H_2 (see Figure 2).

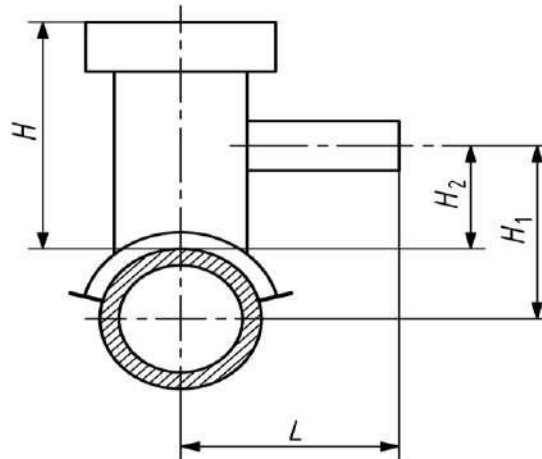

Figure 2 — Dimensions of electrofusion saddle fittings

Where,

- H height of the saddle, which comprises the distance from the top of the main pipe to the top of the tapping tee or saddle
- H_1 height of service pipe, which comprises the distance from the axis of the main pipe to the axis of the service pipe
- H_2 height of service pipe, which comprises the distance from the top of the main pipe to the axis of the service pipe
- L width of the tapping tee, which comprises the distance between the axis of the pipe and the plane of the mouth of the service tee

7.4 Dimensional Stability:

Couplers (including all forms of socket fittings):

All coupler dimensions shall conform to their specified value when the fitting has been stored for a period of 12 months at a temperature of $30 \pm 2^\circ\text{C}$.

Tapping Tees and Branch Saddle:

All tapping tee and branch saddle dimensions shall conform to their specified agreed

values when the fitting has been stored for a period of 12 months at a temperature of 30 + 2°C.

8.0 DOCUMENT REQUIREMENT:

8.1 To Be Submitted Along with Bid

All relevant documents like detailed technical catalogue, technical deviations list (if any) along with quoted price.

8.2 Technical File:

The manufacturer of the fittings shall make availability of a technical file (generally confidential) with all relevant data to prove the conformity of the fittings to this specification. It shall include all results of the type testing and shall conform to the specification relevant technical brochure (e.g. ISO 12093 for electro fusion fittings).

The technical description of the manufacturer shall include the following information:

- a) Field of appliance (pipe and fitting temperature limits SDR's and out of roundness).
- b) Assembly instructions.
- c) Fusion instruction (fusion parameters with limits).
- d) For saddles and tapping tee

The means of attachment (tools and/ or under clamp).

The need to maintain the under clamp in position in order to ensure the performances of the assembly.

For electrofusion fitting, the format of the technical brochure shall conform to ISO DIS 12093.

In the event of modification of the fusion parameters, the manufacturer shall ensure that the joint conforms to this standard.

9.0 QUALITY ASSURANCE PLAN

The Quality Assurance Plan (QAP). Inspection shall be carried out as per **Annexure – I** and the vendor is to submit the plan accordingly. Vendor to submit their own QAP along with offer based on indicative QAP enclosed in this tender for approval to the Owner / Owner's representative

10.0 MARKING:

Following information shall be embossed upto height of 0.15 mm onto the fitting and also in the form of bar code:

- a) Owner name as CUGL.
- b) Manufacturer's name and/or trademark
- c) Material and Designation
- d) Design application series
- e) The size of the fitting in mm
- f) Fusion time in seconds
- g) Cooling time in minutes
- h) Fusion parameters in BAR code
- i) Traceability code (fittings) as per standard ISO 12176-4.
- j) Number of the system standard. This information can be printed/formed directly on the fitting or on a label associated with the fitting or on an individual bag
- k) Production period, year and month

The marking shall stay legible during normal manipulation, storage and installation.

The marking shall not adversely influence the performance of the fitting and prevent the nonconformity of the fitting.

11.0 PACKAGING:

The fittings shall be packaged in bulk or individually protected where necessary in order to prevent deterioration. Whenever possible, they shall be placed in airtight plastic bags in card board boxes or cartons.

The cartons and/or individual bags shall bear at least one label with the manufacturer's name, date of manufacturer, type and dimensions of the part, number of units in the box, and any special storage conditions and storage.

**STANDARD SPECIFICATION ELECTRO FUSION FOR PE
PIPES & FITTINGS**

VPC – SS – PE - 0002

CONTENTS

1.0 ELECTRO FUSION FOR PE PIPE..... 3

1.1 ELECTRO FUSION FITTING JOINTING..... 3

1.2 ELECTRO FUSION JOINTING METHOD / PROCEDURE 4

1.3 RECORDS 5

1.4 TRAINING..... 5

1.5 ELECTRO FUSION SADDLE JOINTING 5

1.6 ELECTRO FUSION SADDLE JOINTING METHOD/ PROCEDURE 6

1.7 RECORDS 7

1.8 TRAINING..... 7

1.9 STOPPING THE GAS FLOW..... 7

1.10 SQUEEZE-OFF 7

1.11 BENDING-BACK 8

1.0 ELECTRO FUSION FOR PE PIPE

1.1 ELECTRO FUSION FITTING JOINTING

1.1.1 For electro fusion fitting jointing, an electrical resistance element is incorporated in the socket of the fitting which, when connected to an appropriate power supply, melts and fuses the materials of the pipe and fitting together.

1.1.2 The effectiveness of this technique depends on attention to the preparation of the jointing surfaces, in particular the removal of the oxidized surface of the pipe over the socket depth and ensuring the jointing surfaces area clean. Also, the pipe should be checked for ovality. If ovality causes a gap between concentrically located pipe and the fitting to exceed 1% of the pipe OD, the pipe must be re-rounded to ensure correct welding. If the gap still exceeds 1% of the pipe OD after re-rounding then a check should be made of the pipe OD dimensions to determine if it meets specification.

Max gap 1% of pipe OD

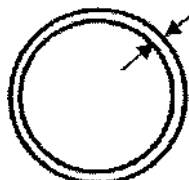

Concentrically Located

Max gap 2% of pipe OD

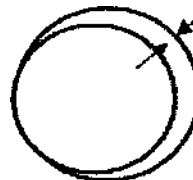

Eccentrically Located

1.1.3 The maximum gap between eccentrically located pipe and fitting i.e. Pipe touching fitting at one point, must not exceed 2% of the pipe OD.

1.1.4 Sometimes coiled pipes may be too oval to fit into couplers, or the end of the pipe may make the alignment of the ends impossible. In such circumstances the use of a mechanical pipe straightener or rounding tool is necessary.

1.1.5 The equipment and procedures following relate to fittings with center stops. If fittings without center stops are used, the maximum insertion depth must be clearly marked on the pipe ends prior to joining (felt tip pen).

Equipment

- The control box input supply to be from a nominal 240V generator, which is normally of approximately 5kVA capacity. The nominal output of the generator is to be 240V +15%, I 0% between no load and full load. Control boxes are to include safety devices to prevent excessive voltages being present at the control box output. The safety device shall operate in less than 0.5s.

Note that extension leads are not to be used on the control box outlet connections.

WARNING: Control boxes are not intrinsically safe and must therefore not be taken into the trench.

- A mechanical pipe surface preparation tool is to be used before fusion is attempted. The tool is to be capable of removing the oxidized surface of the pipe in excess of the insertion depth. The tool is to remove a layer of surface material 0.20.4 mm thick from the outer surface of the pipe preferably in a continuous strip of swarf

over that length and round of the pipe.

- Pipe clamps for restraining, aligning and re-rounding the pipes in the fusion process are to be used.
- Pipe cutters with saw and saw guide.
- Protection against adverse weather conditions.

1.2 ELECTRO FUSION JOINTING METHOD / PROCEDURE

Preparation

- Ensure there is sufficient space to permit access to the jointing area. In a trench, a minimum clearance of 150 mm is required.
- Check that the pipe ends to be jointed are cut square to the axis of the pipe and any burrs removed.
- Wipe pipe ends using clean lint-free material to remove traces of dirt or mud, etc...
- Mark the area over which the oxidized pipe surface is to be removed, i.e. In excess of the insertion depth, on each pipe to be joined by placing the socket of the bagged fitting alongside the pipe end. Trace a line round the circumference at the appropriate distance from the end of the pipe using a felt tip pen or similar.

Note that the fitting should not be removed from the packaging at this stage.

- Connect the electro fusion control box input leads to the generator.
- Check that the reset stop button, if fitted on the control box, is in the correct mode.
- Using the pipe end preparation tool, remove the entire surface of the pipe uniformly, preferably in continuous swarf over the area identified, i.e. In excess of the insertion depth.
- A mechanical scraper could be used however; there is a considerable risk that the end preparation will not be adequate with the use of such a tool.

Note that the prepared pipe surface should not be touched by hand.

- Remove the fitting from its packing and clean the scraped area of the pipe surface and the bore of the fitting with a disposable wipe impregnated with Iso-propanol I Acetone. Ensure the prepared surfaces are completely dry before proceeding.

Note that while Iso-propanol is a suitable cleaner, its use is subject to local Health and Safety Regulations.

- Check that the pipe clamps are of the correct size for the pipes to be jointed.
 - Insert the pipe ends into the fitting so that they are in contact with the center stop.
 - Using the pipe clamps, secure the pipes so that they cannot move during the fusion cycle. Check that the pipe ends and the fitting are correctly aligned.
 - Check that there is sufficient fuel for the generator to finish the joint. Start the generator and check that it is functioning correctly.
 - Switch on the control box.
 - Connect the control box output leads to the fitting terminals and check that they have been fully inserted.
-

If required by the control box enter the fusion jointing time into the control box timer. The jointing time is indicated on the fitting. Check the correct time is shown on the control box display.

Note 1: Automatic control boxes are available which obviate the need to enter the fusion time.

Note 2: Gloves and goggles should be worn during the Fusion process.

- Press the start button on the control box and check that the heating cycle is proceeding as indicated on the display.
- On completion of the heating cycle, the melt indicators should have risen. If there is no apparent move in the melt indicators, the joint should be cut out and a fresh joint made (See note 3 below).
- If a satisfactory joint has been made, the joint is to be left in the clamps for the cooling time specified on the fitting or the automatic control box.

Note 3: If the fusion cycle terminates before completion of the countdown, check for faults as indicated by the control box warning lights and check that there is adequate fuel in the generator. DONOT attempt a second fusion cycle within one hour of cooling of joint at Ambient Temperature of the first attempt.

1.3 RECORDS

Records of appropriate servicing and calibration shall be kept.

1.4 TRAINING

It is necessary that operators, inspection and supervisory personnel acquire the skills of electro fusion fitting fusion. The necessary training should be carried out by a qualified instructor with the objective of enabling participants to;

- Understand the principles of electro fusion fitting jointing.
- Identify pipe and appropriate fitting markings.
- Carry out pre-jointing machine and equipment checks.
- Make satisfactory electro fusion fitting joints from pipes and fittings of different sizes.
- Inspect for and identify joints of acceptable quality.

Note that some form of assessment and certification should be associated with the training. The certificate should detail the pipe and fitting size range. And the equipment used. A register of successful participants should be kept.

1.5 ELECTRO FUSION SADDLE JOINTING

- With electro fusion saddle jointing, an electrical resistance element is incorporated in the base of the saddle which, when connected to the appropriate power supply, melts and fuses the material of the fitting and the pipe together.
 - The success of the technique depends on effective preparation of the jointing surfaces, in particular the removal of the oxidized surface of the pipe over the area equivalent to the area of the saddle base, and cleaning of the pipe surfaces.
 - Methods of holding the tapping tee saddle during the fusion cycle are used namely, top loading and under clamping. The general parameters are similar. In some cases, if
-

the manufacturer's procedure for holding the fitting is provided, then the same should be followed during the fusion cycle.

1.6 ELECTRO FUSION SADDLE JOINTING METHOD/ PROCEDURE

- Expose the pipe onto which the tapping tee is to be assembled, ensuring there is sufficient clear space around the pipe. In a trench, a minimum clearance of 150 mm is required.
- Clean the pipe over the general area on which the saddle is to be assembled using clean, disposable lint-free material.
- Without removing the fitting from its packaging, place it over the required position on the main. Mark the pipe surface all around and clear of the saddle base area using a felt tip pen or similar.
- Remove the surface of the pipe to a depth of 0.2 to 0.4 mm over the full area marked using a suitable tool. Remove the swarf.
- Connect the electro fusion control box input leads to the generator.
- Check that the reset stop button, if fitted on the control box, is in the correct mode.
- Remove the two halves of fitting from its packing and clean the scraped area of the pipe surface and the bore of the fitting with a disposable wipe impregnated with Iso-propanol / Acetone. Ensure the prepared surfaces are completely dry before proceeding.

Note again that while Iso-propanol is a suitable cleaner, its use is subject to local Health and Safety Regulations.

- Position the fitting base onto the prepared pipe surface, and bring the lower saddle into position then gradually and evenly tighten the nuts until the upper saddle makes firm contact with the scraped pipe.
- Check that there is sufficient fuel for the generator to complete the joint. Start the generator and check that it is functioning correctly.
- Switch on the control box if applicable.
- Connect the control box output leads to the fitting terminals and check that they have been fully inserted.
- If required by the control box, enter the fusion jointing time into the control box timer. The jointing time is indicated on the fitting. Check the correct time is shown on the control box display.

Note 1: Automatic control boxes are available which obviate the need to enter the fusion time.

Note 2: Gloves and goggles should be worn during the jointing process.

- Press the start button on the control box and check that the heating cycle is proceeding as indicated on the display.
 - On completion of the heating cycle, the melt indicators, where incorporated should have risen. If there is no apparent move in the melt indicators, a new saddle joint should be made. Cut the tee of the faulty joint from its base.
 - If a satisfactory joint has been made, the joint is to be left in the clamps for the cooling time specified on the fitting label or by the automatic control box.
-

Note 3: If the fusion cycle terminates before completion of the countdown, check for faults as indicated by the control box warning lights and check that there is adequate fuel in the generator. DO NOT attempt a second fusion cycle within one hour of the first attempt.

Note 4: The connection of the service pipe to the fitting outlet should be carried out in accordance with the procedure of the appropriate section of this Item.

Note 5: DO NOT attempt to tap the main with the integral cutter for at least 10 minutes after completion of the cooling cycle.

1.7 RECORDS

Records of appropriate servicing and calibration of Electro Fusion machines/ joints shall be kept.

1.8 TRAINING

AS PER 1.6

Note that some form of assessment and certification should be associated with the training. The certificate should detail the pipe and fitting size range and the equipment used. A register of successful participants should be kept.

1.9 STOPPING THE GAS FLOW

In the operation of a distribution system there is a periodic need to stop the gas flow for either routine or emergency maintenance. The flow may be stopped through the use of installed fittings such as valves. Where installed fittings are not available or the use of such would cause significant supply disruption, then one of the following methods may be employed.

1.10 SQUEEZE-OFF

- To control the gas flow a special tool may be used to squeeze the pipe walls together. Hydraulic jacks are used to supply the necessary force to compress the pipe walls for sizes 90 mm and above.
 - It will be seen the squeeze-off equipment comprises two bars to apply pressure to the outside of the pipe. The bars are brought together, either manually or hydraulically, squeezing the pipe material together until a seal is formed where the upper and lower walls meet.
 - The hydraulic machines should have a spring return for the jack and locking to prevent accidental release of pressure during operation. All squeeze-off machines should be fitted with check plate or stops to avoid over compression of the pipe.
 - Where the pipe walls are compressed the polyethylene pipe will be severely deformed in the regions of maximum compression. The pipe will eventually regain its original shape after squeezing but there will be some reduction in the pressure bearing properties.
 - A complete stop may not always be obtainable because of wrinkling of the inside of the pipe. If a complete stop is required then a second squeeze can be used, with an intermediate vent to remove the gas which passes the first squeeze from say the trench area. A second squeeze-off procedure should be a minimum of three pipe diameters and right angles to the initial squeeze.
 - While not essential it would be good practice to fit a reinforcing stainless steel band do not squeeze again adhesive tape around the pipe upon the completion of a squeezing operation.
-

1.11 BENDING-BACK

Bending back of the pipe may be performed where the pipe has been severed damaged and stopping the gas flow is imperative. Its application is of a temporary nature, and will provide relief until a permanent repair can be affected. The section of pipe, which has been bent back, will have to be replaced because of the damage caused by the severeness of the bend back operation. The need for any bend back operation is most likely to occur as a consequence of damage caused to a PE service pipe.

While it is not the prime function of a saddle tee, controlling the flow in a service may be achieved by opening up on an installed saddle tee and winding down the internal tapping tool to shut off the flow into the service pipe.

PTS- ELECTRO FUSION
FOR PE PIPES & FITTINGS

ANNEXURE # 1

FUSION COUPLERS FORM 20MM TO 180MM

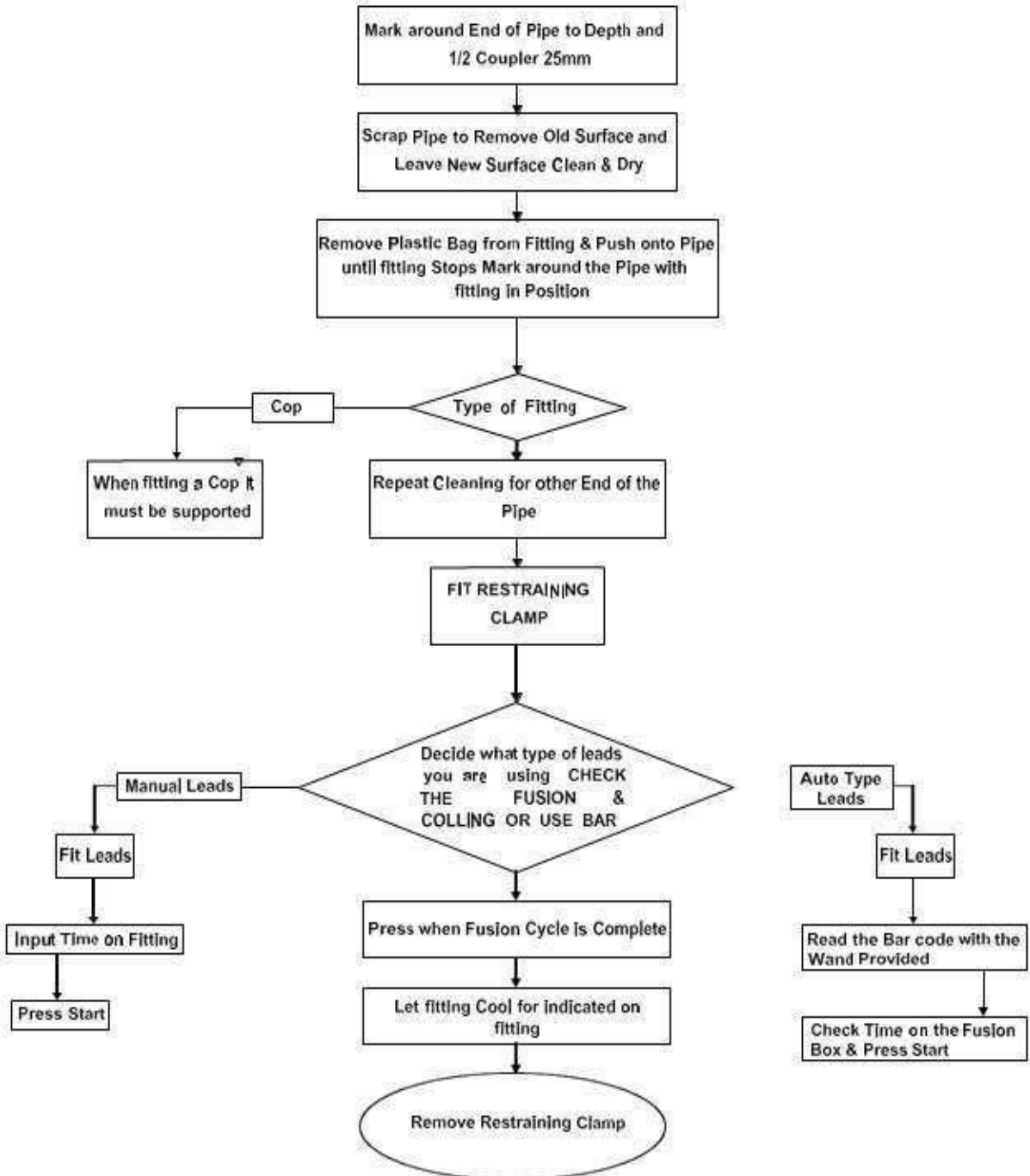

**STANDARD SPECIFICATION – MEDIUM DENSITY
POLYETHYLENE BALL VALVE**

VPC-SS-PE-28

Rev no.	Date	Description	Prepared By	Checked By	Approved By

TABLE OF CONTENTS

1.0	SCOPE	3
2.0	APPLICABLE CODES, SPECIFICATIONS AND STANDARDS	3
3.0	ABBREVIATIONS & TERMINOLOGY.....	4
4.0	TECHNICAL REQUIREMENT	4
5.0	MATERIAL.....	5
6.0	DESIGN.....	6
7.0	DIMENSIONS & TOLERANCE	7
8.0	DOCUMENT REQUIREMENT	7
9.0	QUALITY ASSURANCE PLAN	8
10.0	MARKING	8
11.0	PACKAGING	8

1.0 SCOPE

This technical specification along with datasheet specifies the minimum requirements for design, selection, manufacture, inspection, testing and supply of MDPE Ball Valves and its component made from extruded or injected moulded polyethylene (PE).

This specification elaborates the requirement of MDPE Ball Valve for natural gas distribution systems at operating pressure and operating temperature 4 barg and 250C respectively.

This specification is limited to valves with a nominal diameter (de/do) up to and including 180 mm.

Material of grade shall be PE 100 & SDR 11.

2.0 APPLICABLE CODES, SPECIFICATIONS AND STANDARDS

EN 1555-1: Plastics piping systems for the supply of gaseous fuels- Polyethylene (PE) - part 1: General

EN 1555-2 / ISO 4437-2 / IS-14885: Plastics piping systems for the supply of gaseous fuels- Polyethylene (PE)

EN 1555-3: Plastics piping systems for the supply of gaseous fuels- Polyethylene (PE) - part 3: Fittings

EN 1555-4: Plastics piping systems for the supply of gaseous fuels- Polyethylene (PE) - part 4: Valves

EN 1555-5: Plastics piping systems for the supply of gaseous fuels- Polyethylene (PE) - part 5: Fitness for purpose of the system

EN 1555-7: Plastics piping systems for the supply of gaseous fuels- Polyethylene (PE) - part 7: Guidance for assessment of conformity

ISO TR 13950:1997 or latest edition: Plastics pipes and fittings - Automatic recognition systems for Electro fusions

ISO/IEC 16390:1999 or latest edition: Information technology – Automatic identification and data capture techniques – Bar code symbology specification- Interleaved 2 of 5

ISO 12176-4: Plastics pipes and fittings - Equipment for fusion jointing polyethylene system - part 4: Traceability coding

ISO 17778: Plastics piping systems- Fittings, valves and ancillaries - Determination of gaseous flow rate/pressure drop relationships.

EN ISO 1133, Plastics – Determination of the melt mass-flow rate (MFR) and the melt volume-flow rate (MVR) of thermoplastics

ISO 3126: Plastics piping systems -- Plastics piping systems — Plastics piping components — Measurement and determination of dimensions

PNGRB and other referrals in the above applicable codes.

3.0 ABBREVIATIONS & TERMINOLOGY

d_n / d_o	:	Nominal Outside Diameter
e_n	:	Nominal Wall Thickness
SDR	:	Standard Dimension Ratio = d_n / e_n
LTHS	:	Long Term Hydrostatic Strength (at 20°C for 50yrs)
LCL	:	Lower Confidence Limit – Stress value (MPa) of mean LTHS
MRS	:	Minimum Required Strength – min. value (in MPa) for LTHS of material
C	:	Design Co-efficient – As per ISO: 12162 Table-2
σ_s	:	Design Stress (= MRS/C)
MFR	:	Melt Mass Flow rate – Value related to viscosity of the molten material at a specified temp. and rate of shear. (expressed in g/10min.)
D_f	:	De-rating Co-efficient (Refer Table A.1, Annex A – EN 1555-5)
MOP	:	Maximum Operating Pressure = $(20 \times MRS) / \{(SDR-1) \times C \times D_f\}$
EF	:	Electrofusion

4.0 TECHNICAL REQUIREMENT

4.1 Design of valve shall be as per European Standards EN 1555-4 and the complementary particular requirement.

4.2 Valves shall be leak proof and it is intended to be use in gas distribution networks made of PE pipes and accessories.

4.3 The valves are laid and to be welded by means of electrofusion method.

4.4 The internal and external surfaces of valves shall be smooth, clean and free from scoring, cavities or other surface defects to an extent that would prevent conformity to EN 1555-4.

4.5 No component of valve shall show any damage, scratches, pitting, bubbles, blisters, inclusions or crack.

4.6 Mechanical characteristics of assembled valves:

a) Valve shall have mechanical characteristics conforming to the requirements given in Table-1

of standard EN 1555-4.

- b) Unless otherwise specified by the applicable test method, the test pieces shall be conditioned at (23 ± 2) °C before testing.
- c) Testing of valve shall be in accordance with the test methods as specified in Table-1 of standard EN 1555-4 using the indicated parameters.
- d) Hydrostatic test pressure and minimum test period shall be as per Table-2 of EN 1555-4.

Physical characteristics of assembled valves:

- a) Valve shall have physical characteristics conforming to the requirements given in Table-3 of standard EN 1555-4.
- b) Thermal stability test shall be done at 200 deg. C by means of differential scanning calorimetry (DSC), considering oxygen induction time (OIT) ≥ 20 min.
- c) Melt mass flow rate shall be calculated at 190 deg. C by applying 5 Kg of load on test specimen. It shall be expressed in g/ 10min.
- d) Unless otherwise specified by the applicable test method, the test pieces shall be conditioned at (23 ± 2) °C before testing.
- e) Testing of valve shall be in accordance with the test methods as specified in Table-3 of standard EN 1555-4 using the indicated parameters.

4.8 Performance requirements:

When valves are assembled to each other or to components conforming to other parts of EN 1555, the joints shall conform to EN 1555-5.

4.9 Allowable pressure drop shall be as per the standard ISO 17778.

4.10 Color of valve shall be black.

5.0 MATERIAL

5.1 The PE compound from which the valve body with electrofusion socket is made shall conform to EN 1555-1.

5.2 The PE compound of the valve shall be made only from virgin material conforming to EN 1555-1. PE compound shall be cadmium free pigment compound.

5.3 All parts of the valve in contact with the gas stream shall be resistant to the gas, its condensates and other occurring substances such as dust.

5.4 The PE valves bodies made from below listed material are forbidden:

- a) Use of recycled materials
- b) Mixture of different materials
- c) Addition of complementary materials

5.5 The material and constituent elements used in marking of valve (including elastomers, greases

and any metallic part, if used) shall be resistant to the external and internal corrosion and shall have life expectancy under following conditions at least equal to the PE pipes with which they are intended to be used.

- a) During storage
- b) Under the effect of the gas conveyed
- c) With respect to the services environment and operating conditions

5.6 The seals shall be homogeneous without any inner cracks, inclusion or impurities. It can not contain any component that can alter the properties of the materials they are in contact with.

- a) The nitrile rubber ring shall comply with standard EN 682.
- b) Other seals shall comply with the relevant standard and be suitable for gas service.

5.7 Operating key or extension spindle shall be made of PVC and non-corrosive.

6.0 DESIGN

6.1 Valve will be designed for a maximum operating pressure (MOP) equal to 10 barg.

6.2 The wall thickness of the PE valve body shall be equal or greater than the minimum wall thickness of the corresponding SDR 11 series pipes.

6.3 Valve shall be bi-directional.

6.4 Specified End to End dimension in the Data-Sheet is minimum requirement.

6.5 The design of valve shall be such that, when assembling the valve into the pipe or other components, the electrical coil and/ or seals or any other ancillary parts are not displaced.

6.6 Valve ends shall have extended pipes at both plain ends. Pressure rating and thickness of extended pipes shall be compatible with the pipe in the network.

6.7 Valve ends shall be welded to pipes or fittings by means of electrofusion jointing using coupler.

6.8 Electrofusion socket shall have sufficient fusion compatibility to the pipe to which it is fused to meet the requirement of standard EN 1555-4 and EN1555-5.

6.9 PE valves bodies and their PE electrofusion socket / ends shall have a pressure rating of at least that of the pipe to which they are assembled.

6.10 Valve body and valve ends shall not be bolted and screwed and shall also be designed that it cannot be dismantled.

6.11 Operating Cap/ Head of valve shall be "non-blow out" type. Size of operating cap shall be 50 mm square socket and 40 mm height as per EN 1555-4.

6.12 The running torque of valve shall be as per standard EN 1555-4. Valve shall be designed in such a way that it cannot be easily operated by hand.

6.13 Operating Key or Extension spindle shall be provided for valve operation as per client requirement. Operating key or extended spindle shall be compatible with operating cap.

6.14 The valve should be equipped with a base plate. In order to achieve this, the valve body will be designed with a flat base or with an attached base plate or an integrated one.

6.15 The operating mechanism and the stop wedges will be protected against water intrusion.

6.16 The valve body is completely sealed except a passage for the spindle mechanism.

7.0 DIMENSIONS & TOLERANCE

7.1 The dimensions will be in conformity with the standard EN 1555-3 and EN 1555-4.

7.2 Dimensions shall be measured in accordance with ISO 3126 at (23 ± 2) OC, after being conditioned for at least 4 hrs. The measurement shall not be made less than 24 hrs after manufacture.

7.3 Each valve shall be characterized by its dimensions and associated end connections.

7.4 Technical data given by the manufacture shall include at least following information:

- a) the dimensional characteristics, by working drawings
- b) the assembly instruction

7.5 The dimensions of electrofusion socket shall conform to EN 1555-3, Table-1.

7.6 Pressure rating or thickness of ends shall confirm to interconnecting pipes specification.

7.7 Tolerance for operating cap of valve shall be $(50+0.5)$ mm square for socket and (40 ± 2) mm for height.

8.0 DOCUMENT REQUIREMENT

8.1 TO BE SUBMITTED ALONG WITH BID

All relevant documents like detailed technical catalogue, technical deviations list (if any) along with quoted price.

8.2 TECHNICAL FILE

The manufactures of the valves shall deliver for each type of valve a technical file which includes:

- a) Raw material used.
- b) Drawings, dimensions and tolerances, including for the accessories.
- c) Application range (temperature and pressure limits).
- d) Running torque and initiating torque.
- e) Pressure drop and flow diagram.

- f) Test results and Data proving the conformity of the valve in accordance with EN1555-4 and EN1555-7.
- g) The pipe elements used during valves testing.
- h) The assembly pipes/valves realized during testing shall be in conformity with the manufactures instructions and the extreme installation conditions.
- i) For the test assembly due consideration should be taken regarding the fabrication tolerances and the variation of the outside ambient temperature.

9.0 QUALITY ASSURANCE PLAN

The Quality Assurance Plan (QAP). Inspection shall be carried out as per **Annexure -II** and the vendor is to submit the plan accordingly. Vendor to submit their own QAP along with offer based on indicative QAP enclosed in this tender for approval to the Owner / Owner's representative.

10.0 MARKING

Following information shall be embossed upto height of 0.15 mm onto the valve and also in the form of bar code:

- a) Owner's name as CUGL.
- b) Manufacturer's name and/or trademark
- c) Material and Designation
- d) Design application series
- e) Nominal diameter
- f) Internal fluid gas
- g) Direction of flow
- h) Traceability code (valve and component) as per standard ISO 12176-4.
- i) Number of the system standard. This information can be printed/formed directly on the valve or on a label associated with the valve or on an individual bag
- j) Production period, year and month

The marking shall stay legible during normal manipulation, storage and installation.

The marking shall not adversely influence the performance of the valve and prevent the nonconformity of the valve.

11.0 PACKAGING

The valve and its accessories shall be packaged individually in plastic bags in order to prevent them from deterioration. The valves ends shall be protected with external caps.

The cartons and/or individual bags shall bear at least one label with the manufacturer's name, type and dimensions of the part number, number of units in the box and, any special storage conditions and storage time limits.

	SS – PLB HDPE DUCT	VPC-SS-PE-0024

SS – PLB HDPE DUCT

		ISSUED FOR APPROVAL			
Rev.	Date	Description	Author	Checked	Approved

	SS – PLB HDPE DUCT	VPC-SS-PE-0024

TABLE OF CONTENTS

1.0 INTRODUCTION 3

2.0 SCOPE 3

3.0 REFERENCE DOCUMENTS 3

4.0 PLB HDPE DUCT SPECIFICATIONS 4

5.0 INSPECTION AND ACCEPTANCE TESTS 5

6.0 IDENTIFICATION MARKINGS 7

7.0 INSTRUCTION OF TENDERER 7

8.0 TYPE APPROVAL AND ACCEPTANCE TEST 8

9.0 PACKAGE AND DELIVERY 8

10.0 QUALITY ASSURANCE PLAN 8

1.0 INTRODUCTION

An Optical Fibre (OFC) system for the Telecommunication requirements has been most suitable for City Gas Distribution pipeline project.

For operation and maintenance of the OFC network, it is desired to purchase double layered permanently lubricated (PLB) HDPE duct for use as underground Optical Fibre Cable conduits. The HDPE duct shall be either laid in a trench at a depth of 1.65 meters or shall be laid through HDD (Horizontal direction drilling) and Optical Fibre cable shall be installed using blowing techniques.

2.0 SCOPE

Objective of this specification is to establish minimum requirements to manufacture and supply of HDPE pipes used for laying OFC. This specification covers the minimum generic requirement of permanently self-lubricated high Density Polyethylene ducts (PLB HDPE ducts) for use as underground conduits for optical fibre cables, suitable for installation of OFC by blowing technique.

The scope of the tender will include manufacture/ supply, Inspection / testing / marking / packing / handling and despatch of HDPE pipes as per following specification: per the specification/ requirements given in this document.

Material Grade	50/42, PLB duct as per TEC specifications No. GR/CDS-08/02 Nov 04 or Latest
----------------	---

However Optical Fibre Cable shall be laid in a permanently lubricated HDPE pipe using blowing technique.

All codes and standards for manufacture, testing, inspection etc. shall be of latest edition.

3.0 REFERENCE DOCUMENTS

Unless otherwise specified, this document requires to the latest standards of the following:

TEC/GR/TX/CDS-008/03/MAR-11	Permanently lubricated HDPE telecom Ducts for use as underground optical fiber cable conduits
IS 2530	Method for test for Polyethylene Molding Material and Polyethylene compounds
IS 4984	High Density Polyethylene Pipes for water supply
IS 7328	High Density Polyethylene materials for molding and extrusion
IS 9938	Recommended colours for PVC insulation for LF wires and cables
IS 12235 (Part - 9)	Methods of test for un-plasticized PVC pipes for potable water supplies - Impact strength at 0°C
IS 14151 (Part - 1)	Polyethylene pipes for sprinkler irrigation systems (Part - I Pipes)

ASTMD 1693	Test method for environmental stress cracking of ethylene plastics.
------------	---

4.0 PLB HDPE DUCTSPECIFICATIONS

The PLB HDPE duct shall consist of two concentric layers, the outer layer being HDPE, co-extruded with an inner layer of solid permanent lubricant, to reduce the internal coefficient of Friction (ICF). The lubricant shall be of a solid layer of uniform thickness so formulated to provide a permanent, low friction boundary layer between the innersurface of the duct and Optical Fibre cable. The lubricant layer shall be clearly visible in cross section, concentric with the outer layer.

Alternatively, the duct can be of a homogenous construction (without a separate inner layer) meeting all the requirements of this specification.

The PLB HDPE Ducts shall be supplied in coil form, suitable for shipping and handling purposes.

4.1 Construction

Outer Layer

The base HDPE rein used for the outer layer of the PLB HDPE duct shall conform to any designation of IS – 7328 or to any equivalent standard meeting the following requirements, when tested as per IS – 2530. However, the manufacturers shall furnish the designation for the HDPE resin as permanently IS – 7328 as applicable.

Density	0.940 to 0.958g/cc at 27°C, when tested as per IS: 2530 or IS: 7328
Melt Flow Rate	0.2 to 1.1 g/10 minute at 190°C & 5 kg load, when tested as per IS:2530

Inner Layer

The inner lubrication material shall be of friction reducing, polymeric material which shall be integral with HDPE layer. The lubricant materials shall have no toxic or dermatic hazards for safe handling. In the finished PLB HDPE duct, the co-extruded layer of solid permanent lubricant shall be integral part with HDPE and shall be white in colour and clearly visible in cross-section of duct.

The density of inner layer material shall be white in colour & clearly visible in cross-section of duct. The density of inner layer material shall be between 0.940 and 0.958g/cc at 27°C.

The inner layer of solid permanent lubricant shall be continuous all through and shall not come out during storage, usage and throughout the life of the duct.

4.2 Raw Material

The raw material (s) used for the duct shall meet the following requirements:

- The anti-oxidants used shall be physically harmless.
- None of the additives shall be used separately or together in quantities as to impair long term physical and chemical properties of the duct.

- Single pass rework material of the same composition produced from the manufacturer's own production shall be used and it shall not exceed 10% in any case.
- The raw material used for extrusion shall be dried the moisture content to less than 0.1%.
- Suitable UV stabilizers shall be used for manufacturer of the duct to protect against ultra violet degradation, when stored in open for a minimum period of 8 months.
- The raw material used in the manufacturer of the duct shall be such that the service life of the duct can be expected to be more than 50 years including the life of permanent lubricant.

5.0 INSPECTION AND ACCEPTANCE TESTS:

Bidder shall submit Quality Assurance Plan (QAP) immediately after receipt of order for client's approval. The test and inspection shall be carried out as per the QAP in accordance with the codes and standards outlined in the specification. Following test shall be conducted as a minimum as per the codes and standards indicated in this document in the manufacturer's premises. Test results must comply with specifications as per TEC GR Nos. TEC/GR/TX/CDS-008/03/MAR-11, including all the other requirements, which are necessary

CUGL reserves the right to carry out inspection at vendor place, as per approved QAP, By CUGL representative or representative of the any third party agency nominated by CUGL. Notice for inspection shall be given to CUGL/PMC at least one week in advance.

5.1 Visual Inspection

The ducts shall be checked visually for ensuring good workmanship that the ducts shall be free from blisters, shirks hole, flaking, chips, scratches, roughness, break and other defects. the ducts shall be smooth, clean, round. The ends shall be cleanly cut and shall be square with axis of the duct.

The colour of the duct shall be green and uniform throughout. Each duct shall contain 4 approximately equi-spaced continuous longitudinal stripes of width 3-mm minimum in white colour. These stripes shall be co-extruded during manufacturing. The material of the stripes shall be same as that of base compound for the duct.

In the case of two-layer construction the inner layer (Soil Lubricant) shall be white in colour.

The colours of the duct, stripe and inner layer (in the case of two-layer construction) shall be identifiable under normal lighting conditions and generally conform to IS- 9938.

5.2 Dimension of Ducts

Please refer Technical data sheet

5.3 Tensile Strength and Elongation

The samples removed from the PLB HDPE ducts when tested as permanently IS- 14151 (Part – I)

5.4 Reversion Test

The test shall be carried out as per IS-4984. For this purpose, a duct length of 200 mm shall be placed horizontally in an air-oven or a suitable liquid bath on a support at

110 ± 2°C for 60 ± 1 minutes so that the dimensional change in duct section are not impeded. After cooling to room temperature, the dimensional change of the duct section shall be measured in the longitudinal direction and the deviation from the initial length shall be calculated and stated in percentage. The dimensions shall not change by more than 3% in the longitudinal direction.

5.5 Environmental Stress Crack Resistance Test

The specimen cut from the PLB HDPE ducts shall meet the environmental stress cracking as described in ASTM D-1693.

5.6 Impact Strength Test

The test has to be carried as per IS-12235 (Part – 9). A sample duct 150 mm in length shall be placed on heavy rigid block whose faces are at an angle of 120°. A striker with a hemispherical nose of 13 mm radius and loaded to a total weight of 10 kg shall be allowed to fall freely in a suitable vertical guide through a height of 1.5 m before striking the duct. The line of fall of the striker shall coincide with the diameter of the duct. The duct shall not crack or split.

5.7 Crush Resistance Test

Samples of duct of 150 mm ± 2 mm in length shall be subjected to a dead load of not less than 50 kg for one minute and shall be allowed to recover for 5 minutes. The deflection with load on and after recovery period shall not exceed 10% and 2% respectively.

5.8 Mandrel Test

A 150-mm long mandrel of diameter, 3 mm less than the internal diameter of the duct shall be passed through a 5-meter length of duct, freely throughout the length, when the duct is bent to a radius of 5 meters.

5.9 Ovality Test

Ovality is the difference between maximum outside diameter and the minimum outside diameter at the same cross-section of the duct, at 300 mm away from the end.

5.10 Coil Set Test:

The PLB HDPE duct shall unroll of the drums without snaking or waving having zero coil set. Thus, the duct shall lay straight into the trench without re-coiling. For this purpose, when a minimum length of 50 meters duct taken from the coil and laid on the ground, it shall be straight without any bends or kinks and without deformation, except 5 meters from each end.

5.11 Oxidation Induction Test:

The induction time in oxygen when tested with a copper pan as per method specified in IS_4984 and, shall not be less than 30 minutes.

5.12 Hydraulic Characteristics:

The duct shall be tested for internal pressure creep rupture test as per IS-4984. For this purpose, a sample length of 10 times the outside diameter of the duct shall be taken. At the end of the test, the sample shall not show signs of localised swelling or leakage and shall not burst during the test duration. The test showing failure within a distance equivalent to the length of end cap from the end shall be disregarded and the test repeated.

5.13 Internal Co-efficient of Friction:

The internal Co-efficient of Friction when tested as permanently method, shall not exceed 0.06 when tested with respect to Nylon jacketed unarmoured Optical Fibre Cable i.e., 48 F Fibre as required.

5.14 Optical Fibre Cable Blowing Test:

For this test an Optical Fibre Cable of a diameter nearest to the diameter indicated in this specification, relevant to the size of duct under test shall be installed by blowing of the cable in a length of 1 km of the duct. The duct shall be laid with bends in the horizontal and vertical planes and a raise in the middle. The 1 km section shall include two couplings at suitable locations.

The OFC shall then be blown out. It shall be inspected for any visual damage. The OFC shall then be blown in again.

It shall be possible to blow in the Optical Fibre Cable through the 1 km duct, each time in not more than 30 minutes. There shall be no visible damage to OFC. The test will be conducted on two samples out of the five submitted for Type Approval.

6.0 IDENTIFICATION MARKINGS

The duct shall be prominently marked with indelible ink, with the following information at intervals every meter to enable identification of the pipe. The size of ink markings shall be distinct, clearly and easily visible.

- CENTRAL UP GAS LIMITED
- CUGL Logo
- Manufacturer's Name
- Name of the duct with size
- Designation of the Pipe
- Date of manufacturing
- Sequential length marking at every meter.

Marking shall be done in continuous length of pipe as per TEC. In addition to the above the pipe shall be marked as "CUGL" in continuous lengths at interval of 1 m.

7.0 INSTRUCTION OF TENDERER

7.1 Length of Pipe:

Length of the Pipes and their supply will be as per following: -

DN 50mm-In coils of 500 Mtrs. each

7.2 Protection:

The ends shall be protected by proper end caps to prevent from shocks and ingress of the foreign body.

7.3 Documents to be submitted

- The successful bidder shall submit following for approval of Purchaser/ Consultant after placement of order
- The quality Assurance Plan (QAP & Sampling Plan)

- Material Test report as per TEC
- Performance Requirements (TEC)
- Type Test (as per TEC)

7.4 Bidder shall submit following documents at the time of bidding,

- BIS Certification
- List of current orders in hand for similar items with full details such as specification, name of purchaser etc.
- Details of the largest supply executed
- Name and address of proposed test laboratories along with their credentials / past records for carrying out all required tests.

8.0 TYPE APPROVAL AND ACCEPTANCE TEST:

All the tests mentioned in this document shall be carried out on the 5 standard lengths of ducts and the samples must pass these tests before according the type approval. The supplier shall furnish 5 standard length for carrying out these tests for according type approval. Bulk manufacturer and supply shall start only after issue of type approval. The type approval certificate shall clearly be indicated the type/ grade/ source of high-density polyethylene raw material, the size of the duct and the construction of the duct i.e., Two layer of Homogenous.

8.1 Acceptance Test

The acceptance tests shall be carried out on samples from the lot for Dimensional and Visual requirements. The requirements for Tensile Strength & Elongation, Reversion Test, Environmental Stress Crack resistance, Impact Strength, Crush resistance, Oxidation Induction Test, Hydraulic Characteristics and internal Coefficient of Friction shall be carried out.

9.0 PACKAGE AND DELIVERY

The store shall be supplied in coils of suitable size for delivery in such a manner that they arrive at their distribution in a safe and undamaged condition and will permit the loading, unloading and handing the stores using standard moving equipment. The minimum inner bending diameter of technical coiled duct shall be 25 times the outer diameter of the cut. The material used for packaging wrapping sealing, moisture, resistant, corrosion prevents etc. as per applicable shall be of recognized brands and shall conform to best standards for packaging. The packing shall protect the material from impact vibration rough handling rain, dust, damp, insects, rodents etc., Each packing should have packing slip and test dispatch clearance documents.

10.0 QUALITY ASSURANCE PLAN

1. Vendor shall submit the details for Quality Assurance Plan followed by them, beginning with raw materials, fabricated components, assemblies, etc., to finished product (As Applicable).
2. The Owner reserves the right to inspect and test duct at all stages of production and testing. The inspection and testing shall include but not be limited to materials, subassemblies, prototypes, produced units, guaranteed, performance specifications etc.

3. For factory inspection and testing, vendor shall arrange all the requirement e.g., quality assurance personnel spaces, test gear etc., for successful carrying out of the job by the Owner's respectively at vendor's cost at the vendor's/ Manufacturer 's works
4. Vendor shall invite the Owner, at least 30 days in advance, of the date on which material shall be ready for inspection and testing. All relevant documents and manuals approved engineering drawings, etc. shall be provided to the Owner well in advance of the start of inspection and Testing.
5. Owner shall, after completion of inspection and testing to their satisfactory, issues factory acceptance certificate to release duct for shipment. No Duct shall be shipped under any circumstances unless a factory acceptance certificate has been issued for it, unless agreed otherwise by Owner.
6. The observation and test results obtained during various tests conducted shall be complied and documented to produce test reports by vendor. The test reports shall be given for each equipment / items and system as a whole.

STANDARD SPECIFICATION – WARNING MAT

VPC –SS-PE-0013

REV. No	DATE	Purpose	Prepared By	Checked By	Approved By
--------------------	-------------	----------------	------------------------	-----------------------	------------------------

CONTENTS

1.0	SCOPE	3
2.0	DEFINATIONS	3
3.0	REFERENCE CODE	3
4.0	FEATURES	3
5.0	QUALITY ASSURANCE (QA).....	4
6.0	DEFECT LIABILITY	4
7.0	APPENDIX - I.....	4
8.0	RECOMMENDED MANUFACTURER FOR RAW MATERIAL.....	4

1.0 SCOPE

The present document covers the technical specifications for the procurement of Warning Mat. Warning mats shall be laid in the ground above the gas main line in order to indicate their presence.

2.0 DEFINITIONS

Owner	Shall mean Central UP Gas Limited (CUGL)
Manufacturer	Means the Manufacturer of the Warning Tap/Mat
SS	Means the present <<Standard Specification>>
TPIA	Means the Inspection Agency to be appointed by Owner.

3.0 REFERENCE CODE

IS 10889	High Density Polyethylene Films
ASTM D - 638	Standard test method for tensile properties of plastics.

4.0 FEATURES

- **Material**

Raw material of the warning mat shall be Virgin material.

The material grade of Warning Mat shall be HDPE with warning sticker / stamp.

- Mechanical properties
- Tensile strength at break (Machine direction) - 300 Kgf /cm²(minimum)
- Elongation in machine & Transverse direction (%) - 300 (minimum)

- **Colour**

The Mat shall be of bright golden yellow colour. This colour must not take any appreciable alteration in the course of time.

- **Dimensions**

Warning Mat shall have following dimensions:

Width 300 mm ± 5 mm

Thickness 1 mm (Minimum)

Negative tolerance on thickness is not allowed.

- **Marking**

- Marking on the Mat shall be approved by owner. The warning Mat shall be provided with Chainage marking and the warning mat must be engraved with "Caution: High pressure gas pipeline below" in both English and Hindi along with OWNER's Logo at a frequency of every meter.
- Vendor shall submit proposed Artwork to be marked on the Mat for the approval from Owner / Owner's Consultant.

- **Tests**

- a. Colour- Fast test

Test specimen 100 mm to 150 mm wide shall be immersed in a 20% solution of ammonium sulphide at 15 to 20 °C temperature for 15 days. The colour fastness shall be evaluated by comparing the test specimen with a sample specimen. The comparison shall be made by placing the two specimens on a white back ground in day light, but without exposing them directly to sun light. Test shall be accepted satisfactory, if the colour of the strip remains intact.

- b. Other tests shall be carried out as per relevant national / international standard enclosed in QAP.

- **Packing**

The warning mat shall be delivered in rolls of 50meters. Packing size to be mentioned to ensure uniformity in delivery conditions of the materials being procured. Bidder shall submit the packing details during offer and also compiled with at the time of delivery.

5.0 QUALITY ASSURANCE (QA)

Manufacturer shall prepare detailed QAP and submit for the approval from Owner / Owner's Consultant.

6.0 DEFECT LIABILITY

Defect liability period shall be as per the commercial volume I of II

7.0 APPENDIX - I

Vendor to submit the following Data along with BID.

SR.NO.	DESCRIPTION	UNIT	DATA	REMARKS
01.	Average gravimetric Thickness	mm		
02.	Tensile strength at Break (in machine direction)	Kg / cm ²		
03.	Tensile strength at Break (in Transverse direction)	Kg / cm ²		
04.	Elongation at Break (in Transverse direction)	%		
05.	Elongation at Break (in Transverse direction)	%		
06.	Color bleeding	-		
07.	Dimensional stability	% change		

8.0 RECOMMENDED MANUFACTURER FOR RAW MATERIAL

- SOLVAY
 - BOREALIS
 - TOTAL PETROCHEMICALS
-

- DOW
- ELENAC
- RELIANCE
- GAIL
- HALDIA

However, any other reputed national or international Manufacturer may also be considering for supply of Raw material with approval of Owner/ Owner's representative.

STANDARD SPECIFICATION – SUPPLY GI PIPES

VPC – SS – PE - 0005

REV. No	DATE	Purpose	Prepared By	Checked By	Approved By
--------------------	-------------	----------------	------------------------	-----------------------	------------------------

By

CONTENTS

1.0	INTRODUCTION AND SCOPE.....	3
2.0	DEFINITIONS.....	3
3.0	MATERIAL	3
4.0	DIMENSIONS, THICKNESS & DIMENSIONALTOLERANCES.....	3
5.0	END CONNECTION OF PIPE	3
6.0	TECHNICAL SPECIFICATION FOR GI PIPES.....	4
7.0	FREEDOM FROM DEFECTS.....	4
8.0	GALVANIZING.....	5
9.0	PRESSURE TEST.....	5
10.0	MARKING	5
11.0	INSPECTION / DOCUMENTS	6
12.0	PACKAGING.....	6

1.0 INTRODUCTION AND SCOPE

Owner plans to augment Piped Natural Gas (PNG) network. It supplies natural gas to domestic & commercial and few industrial customers.

This present document covers the technical specification for the procurement of GI Pipes used in high pressure natural gas transportation and distribution systems. It describes the general requirements, controls, tests, QA/QC examination and final acceptance criteria which need to be fulfilled.

This specification covers the requirements for GI pipes of heavy steel tube. Unless modified by this specification, requirements of IS 1239 (Part-I): 2004 (Latest edition) shall be valid.

2.0 DEFINITIONS

Owner	Shall mean Central UP Gas Limited. (CUGL)
Manufacturer	Means the Manufacturer of the GI pipe.
SS	Means the present <<Standard Specification>> and all its appendix, if any.
TPIA	Means the Inspection Agency to be appointed by Owner.

3.0 MATERIAL

The material used for the manufacturing of GI pipes confirming to IS 1239 (Part -1): 2004 (Latest edition).

4.0 DIMENSIONS, THICKNESS & DIMENSIONALTOLERANCES

The dimensions & nominal mass of tubes shall be in accordance with Table 5 subject to the tolerances permitted in CL.8.1 & 9 of IS 1239 (Part-I) : 2004 (Latest edition). Length of each pipe shall be 6 mtrs with + 6, - 0 mm tolerance. However, pipe length shall be considered 6 m. only for measurement / payment purpose.

Nominal Diameter DN	15 mm	20 mm
Grade	Heavy	Heavy
Outer Dia. (Max. / Min.)	21.8 mm / 21.0 mm	27.3 mm / 26.5 mm
Thickness (mm)	3.2	3.2
Nominal weight (Kg / m)	1.44	1.87

5.0 END CONNECTION OF PIPE

GI Pipes shall be supplied with plain end.

6.0 TECHNICAL SPECIFICATION FOR GI PIPES

Service :	Natural Gas
Working Pressure :	4 bar (g)
Hydrostatic Test Pressure :	6 bar (g)
Working Temperature :	0°C to 50°C
Material Description :	IS:1239 (Part-I) Heavy Duty, Continuous Welded
Min. Tensile Strength :	30 kgf/sq.mm
Min. Elongation :	6%
Tolerance :	+ Not limited, - 10%
Protective Coating :	Galvanised uniformly to protect from
corrosion as per IS:	4736/ ASTM A53 or by Electro Galvanising
Ends of Pipes :	Plain End
Inspection :	Inspection shall be carried out as per applicable code & approved QAP and 100% Pressure Testing shall be carried out at factory

7.0 FREEDOM FROM DEFECTS

On visual examination the outside & inside surfaces of pipes shall be smooth & free from defects such as cracks etc.

8.0 GALVANIZING

- Pipes shall be galvanized to meet the requirement of IS: 4736 – 1986 with latest amendment.
 - Zinc conforming to any grade specified in IS: 13229- 1991 with latest amendment shall be used for the purpose of galvanizing.
 - Galvanizing bath: The molten metal in the galvanizing bath shall contain not less than 98.5% by mass of zinc.
 - Mass of zinc coating: Minimum mass of zinc coating determined as per IS: 6745 shall be 360gms/m².
 - Uniformity of galvanized coating: The galvanized coating when determined on a 100 mm long test piece in accordance with IS 2633: 1986 with latest amendment shall withstand 5 one – minute dips.
 - Freedom from defect: The zinc coating on internal & external surfaces shall be uniform adhered, reasonably smooth & free from such imperfections as flux, ash & drop inclusions, bare patches, black spots, pimples, lumpiness runs, rust stains, bulky white deposits & blisters. Rejection & acceptance for these defects shall be as per Appendix - A of IS 2629: 1985 with latest amendments.
-

- **Samplings**

- a) All materials of the same type in coating bath having uniform coating characteristics shall be grouped together to continue a lot. Each lot shall be tested separately for the various requirements of the specification. The number of units to be selected from each lot for this purpose shall be IS:4711 1995 with latest amendment.
- b) The sample selected according to Clause 6.1 & 6.2 of IS: 4736 – latest edition.
- c) The sample found conforming to above requirements shall then be tested for mass of zinc coating in accordance with Clause 5.1 of IS: 4736 – 1986 with latest amendment.
- d) Criteria for conformity: As per IS: 4736 – 1986 with latest amendments.

9.0 PRESSURE TEST

Hydrostatic pressure test shall be carried out at a pressure of 5 Mpa for the duration of at least 3 second and shall not show any leakage in the pipe. Vendor to submit the internal pressure test certificate for the same. Owner Representative or Third party Inspection Agency appointed by Owner shall witness finish goods testing as per the sample procedure specified in IS: 1239 (Part-1) – latest edition.

10.0 MARKING

Each pipe shall be embossed with Owner's logo, manufacturer's name or trademark, size designation, class of pipe at the interval of not more than 1 meters.

Each packing containing pipes shall carry the following embossed, stamped or written by indelible ink.

- Manufacturers name or trademark.
- Class of pipe –Heavy.
- Indian standard mark (ISI).
- Lot number / Batch no. of production.

Each pipe conforming to this standard shall also be marked with BIS standard mark.

11.0 INSPECTION / DOCUMENTS

Inspection shall be carried out as per Owner Technical Specification.

Owner Representative or Third Party Inspection Agency appointed by Owner shall carry out stage wise inspection during manufacturing / final inspection.

The manufacturer shall have a valid license to use ISI monogram for manufacturing of pipe in accordance with the requirement of IS: 1239.

Vendor shall furnish all the material test certificates, proof of approval / license from specified authority as per specified standard, if relevant, internal test / inspection reports as per Owner Tech. Spec. & specified code for 100% material, at the time of final inspection of each supply lot of material.

For any control, test or examination required under the supervision of TPIA/Owner/Owner's representative, latter shall be informed in writing one (1) week in advance by vendor about inspection date and place along with production schedule.

Even after third party inspection, Owner reserves the right to select a sample of pipes randomly from each manufacturing batch & have these independently tested. Should the results of these tests fall outside the limits specified in Owner technical specification, then Owner reserves the right to reject all production supplied from the batch.

12.0 PACKAGING

Packing size to be mentioned to ensure uniformity in delivery conditions of the material being procured. Bidder shall submit the packaging details during QAP and also complied with at the time of delivery.

**STANDARD SPECIFICATION FOR PURE POLYESTER POWDER
COATING**

VPC -SS-PE-0011

REV	DATE	Purpose	Prepared By	Checked By	Approved By
00	18.06.18	ISSUED AS STANDARD	BS	MVK	AD

CONTENTS

1.0	SCOPE	3
2.0	SPECIFICATION FOR POWDER COATING	3
3.0	TESTING	3
4.0	MARKING	3
5.0	INSPECTION/ DOCUMENTS.....	4

1.0 SCOPE

This Specification specifies the requirements for powder coating (Pure Polyester) of GI Pipes & fitting suitable to use for carrying Natural Gas directly expose to sunlight.

2.0 SPECIFICATION FOR POWDER COATING

Powder Material	:	Pure Polyester.
Application	:	Electrostatic Spraying (40 – 90 KV Manual/ Automatic)
Backing Schedule	:	180 ⁰ C to 200 ⁰ C for 10 mm (Metal Temperature) Coating
Thickness	:	50-60Microns

3.0 TESTING

Film Type	:	Glossy/Satin 86
Gloss600	:	95%
Cross Hatch Adhesion (ASTM D-5870)	:	GT = 0/100
Cylindrical bending Test (ASTM D -522) 5mm Rod dia	:	Passes
Enrichsen cupping (min)	:	8 Passes
Pencil Hardness(mm)	:	2H
Scratch Resistance (Kg. Mm)	:	3
Impact Resistance Kg. Min (ASTM D- 2794)	:	Direct 150 Indirect 150
Salt Spray Resistance (ASTM B-117)	:	1000 Hrs. (min)
Porosity (DIN 53161)	:	Passes
Humidity Resistance	:	1000 Hrs. (min)

4.0 MARKING

Each fitting shall be embossed with manufacture's name or trademark and the size designation. Each packing containing fittings shall carry the following stamped or

written by indelible ink.

- Manufacturers name or trademark.

- Designation of fitting.
- Lot number.

Each fitting conforming to this standard shall also be marked with BIS standard mark.

5.0 INSPECTION/ DOCUMENTS

- Inspection shall be carried out as per OWNER Technical Specification.
- OWNER representative or Third-Party Inspection Agency appointed by OWNER shall carry out stage wise inspection during manufacturing/final inspection.
- Vendor shall furnish all the material test certificates, proof of approval/ license from specified authority as per specified standard, if relevant, internal test inspection reports as per OWNER Tech Spec. &- specified code for 100% material, at the time of final inspection of each supply lot of material.
- Even after third party inspection, OWNER/ OWNER's Consultant reserves the rights to select a sample of fittings randomly from each manufacturing batch & have these independently tested. Should the results of these tests fall outside the limits specified in OWNER technical specification, then OWNER/ OWNER's Consultant Reserves the rights to reject all production supplied from the batch. **(ASTM D- 2247)**

Weathering : 60-70% Gloss retention after 1000Hrs.

(sun test with water
immersion, Xenon
150K.lux)

Colour : Light colour as approved by OWNER/CONSULTANT

STANDARD SPECIFICATION - SUPPLY GI FITTINGS

VPC-SS-PE-0006

00

REV. No	DATE	Purpose	Prepared By	Checked By	Approved By
--------------------	-------------	----------------	------------------------	-----------------------	------------------------

CONTENTS

1.0 SCOPE..... 3

2.0 DEFINATIONS 3

3.0 MATERIAL..... 3

4.0 DIMENSIONS THICKNESS & DIMENSIONAL TOLERANCES..... 3

5.0 WEIGHT 3

6.0 THREADS..... 3

7.0 FREEDOM FROM DEFECTS 4

8.0 GALVANIZING 4

9.0 PRESSURE TEST 4

10.0 COMPRESSION TEST 4

11.0 SAMPLING 4

12.0 MARKING..... 5

13.0 PACKAGING 5

14.0 INSPECTION / DOCUMENTS 5

1.0 SCOPE

Owner plans to augment Piped Natural Gas (PNG) network. It supplies natural gas to domestic & commercial and few industrial customers.

This present document covers the technical specification for the procurement of GI fittings used in high pressure natural gas transportation and distribution systems. It describes the general requirements, controls, tests, QA/QC examination and final acceptance criteria which need to be fulfilled.

This specification covers the requirements for Malleable Cast Iron Fittings unless modified by this specification, requirements of IS 1879 – latest edition shall be valid.

2.0 DEFINATIONS

Owner	Shall mean Central UP Gas Limited (CUGL)
Manufacturer	Means the Manufacturer of the GI fittings.
SS	Means the present <<Standard Specification>>and its appendix, if any.
TPIA	Means the Inspection Agency to be appointed by Owner.

3.0 MATERIAL

The material used for the manufacturing of GI fittings shall conform to ISI 14329 – 1995 with latest amendments Grade BM 300. Relevant test certificates conforming to all the test agreements of IS 14329 shall be provided with fittings.

4.0 DIMENSIONS THICKNESS & DIMENSIONAL TOLERANCES

- Dimensions of various types of fittings shall be as specified in sections 2 to 10 of IS 1879 – 1987 with latest amendments, as applicable.
- Wall thickness of fittings and tolerances on them shall be as given in Table 1.2 of S 1879 – 1987 with latest amendments,
- In case of reducing fittings, the dimensions at each outlet shall be those appropriate to the nominal size of the outlet.
- Elbows, Tees, Sockets and caps shall be of reinforced type.

5.0 WEIGHT

Weights of various types of fittings shall be as specified in sections 2 to 10 of S 1879 – 1987 with latest amendments, as applicable.

6.0 THREADS

- Threads shall be NPT type and conforming to ASME B1.20.1.
 - Outlets of fittings shall be threaded to dimensions & the tolerances as specified in ASME B1.20.1.
 - All internal & external threads shall be tapered.
 - For checking conformity of threads gauging practice in accordance with ASME B1.20.1
-

shall be followed.

- Chamfering: The outlet of fittings shall have chamfer.

7.0 FREEDOM FROM DEFECTS

On visual examination, the outside & inside surfaces of fittings shall be smooth & free from any defects such as cracks, injurious flaws, fine sand depth etc.

8.0 GALVANIZING

- Fittings shall be galvanized to meet the requirement of IS: 4759-1996 with latest amendments.
- Zinc conforming to any grade specified in IS: 13229-1991 with latest amendments shall be used for the purpose of galvanizing.
- Galvanizing bath: The molten metal in the galvanizing bath shall contain not less than 98.5% by mass of zinc.
- Coating requirements: Mass of coating shall be 610 - 700gms/m².
- Freedom from defect: The zinc coating shall be uniform adhered, reasonably smooth & free from such imperfections as flux, ash bare patches, black spots, pimples, lumpiness runs, rust stains, bulky white deposits & blisters.
- **Samplings**
 - a. All materials of the same type in coating bath having uniform coating characteristics shall be grouped together to continue a lot. Each lot shall be tested separately for the various requirements of the specification. The number of units to be selected from each lot for this purpose shall be given in Table 2 of IS 4759 - latest edition.
 - b. The sample selected according to Column 1 & 2 of Table 2, IS: 4759 - latest edition shall be tested for visual requirements as per Clause 6.2 of IS: 4759 - latest edition
 - c. The sample found conforming to above requirements shall then be tested for mass of zinc coating in accordance with Clause 9.2 of IS: 4759 - latest edition.
 - d. Criteria for conformity: As per Clause 8.3 of IS: 4759-latest edition.
 - e. Test procedure shall be as per Clause 9 of IS: 4759-latest edition.

9.0 PRESSURE TEST

Vendor shall carry out pneumatic pressure test as per Clause 11.1b of 1879 - 1987 with latest amendments on each & every fittings. Vendor to submit the Internal Quality control certificate for the same. Owner shall witness pneumatic testing as per the sampling procedure specified in 1879 - 1987 with latest amendments.

10.0 COMPRESSION TEST

This test shall be conducted to judge the malleability of the pipe fittings & shall be carried out as per Clause 12 of 1879 - 1987 with latest amendments.

11.0 SAMPLING

Owner Representative of Third Party Inspection Agency appointed by Owner shall witness the tests as per clause 14 of 1879 – 1987 with latest amendments. However, vendor to perform 100% inspection of visual, dimensional & pressure test. Vendor shall furnish Internal test certificates at the time of final inspection to the Owner.

12.0 MARKING

Each fitting shall be embossed with OWNER's logo, manufacturer's name or trademark and the size designation.

Each packing containing fittings shall carry the following embossed, stamped or written by indelible ink.

- Manufacturer's name or trademark.
- Designation of fittings.
- Lot number.

Each fitting conforming to this standard shall also be marked with BIS standard mark.

13.0 PACKAGING

Packing size to be mentioned to ensure uniformity in delivery conditions of the material being procured. Packing size shall be approved by owner / owner's representative before packing the material. The vendor shall submit the packaging details during QAP and also complied with at the time of delivery.

14.0 INSPECTION / DOCUMENTS

- Inspection shall be carried out as per Owner Technical Specification.
 - Owner Representative or Third-Party Inspection Agency appointed by Owner shall carry out stage wise inspection during manufacturing / final inspection.
 - Vendor shall furnish all the material test certificates, proof of approval / license from specified authority as per specified standard, if relevant, internal test / Inspection reports as per Owner Tech Spec. & specified code for 100% material, at the time of final inspection of each supply lot of material.
-



HEALTH, SAFETY AND ENVIRONMENT [HSE] SPECIFICATIONS

1.0 SCOPE

These specifications establish the 'Health, Safety and Environment [HSE] Management' requirement to be complied with by the Contractors during executing their Job. Requirements stipulated in these specifications shall supplement the requirements of 'HSE Management' given in relevant act(s) / legislation(s).

2.0 REQUIREMENTS OF 'HEALTH, SAFETY AND ENVIRONMENT [HSE] MANAGEMENT SYSTEM' TO BE COMPLIED BY BIDDERS

- 2.1** Preferably, the Contractor should have a documented 'HSE Policy' to cover commitment of their organization to ensure health, safety and environment aspects in their line of operations or they must follow the 'HSE policy' of CUGL for safe execution of work.
- 2.2** The Contractor shall ensure that the CUGL's 'Health, Safety and Environment [HSE]' requirements are clearly understood and faithfully implemented at all level, at sites.
- 2.3** Contractor shall promote & develop consciousness for Health, Safety & Environment among all personnel working for the Contractor. Regular work-site meetings (Tool box talk) shall be arranged as 'HSE' activities to cover hazards involved in various operations during executing their jobs, location of First Aid Box, trained personnel to give First Aid, Assembly Points, and fire protection measures such as water and fire extinguishers etc.
- 2.4** Non-conformance of 'HSE' policy and directives as per CUGL by Contractor [including their sub-Contractors] as brought out during review/audit by CUGL / external agency authorized by CUGL, shall be complied by Contractor and its report to be submitted to CUGL.
- 2.5** Contractor shall adhere consistently to all provisions of 'HSE' requirements. In case of non-compliance of continuous failure in implementation of any of the 'HSE' provisions, CUGL may impose penalty and subsequent stoppage of work for non-compliance. The decision of imposing monetary penalty & work-stoppage shall be taken by EIC with consultation with Safety Officer of CUGL.
- 2.6** All fatal accidents and other personnel accidents shall be investigated for root cause by CUGL and Contractor shall extend all necessary help and cooperation in this regard. Recommend corrective and preventive actions of findings will be communicated to Contractor for taking suitable actions should be taken by the Contractors to avoid recurrence of such incidences.
- 2.7** Contractor shall ensure that all their staffs and workers, including their sub-Contractor(s), shall wear 'Personal Protective Equipments [PPEs]' such as safety helmets, safety shoes, safety belts, dust mask, ear plug, protective goggles, gloves, etc., as per job requirements. All these gadgets shall conform to relevant IS specifications or equivalent.
- 2.8** Contractor shall assign competent & qualified personnel for carrying out various tasks/jobs as per requirement.



HEALTH, SAFETY AND ENVIRONMENT [HSE] SPECIFICATIONS

- 2.9 All equipments should be tested and certified for its capacity before use.
- 2.10 Contractor shall ensure storage and utilization methodology of materials that are not detrimental to the environment. Where required, Contractor shall ensure that only the environment-friendly materials are used.
- 2.11 All persons deployed at site shall be knowledgeable of and comply with the environmental laws, rules and regulations relating to the hazardous material substances and waste. Contractor shall not dump release or otherwise discharge of dispose-off any such materials without the express authorization of EIC of CUGL.
- 2.12 Contractor should obtain all work permits before start of activities [as applicable] like hot work, cold work, confined space, electrical isolation, work at heights and its use & implement all precautions mentioned therein.
- 2.13 Contractor should display at site office and work locations caution boards, provide posters, banners for safe working to promote safety consciousness, etc.
- 2.14 Contractor should properly barricade the facility where work is in progress for safe working and reclaim the work zone after completion of work to promote safety consciousness.

3.0 RELEVANT CODES FOR 'PERSONAL PROTECTION EQUIPMENTS'

IS: 2925 - 1984	Industrial Safety Helmets
IS: 47701 - 1968	Rubber Gloves for Electrical Purpose
IS: 6994 - 1973 [Part-I]	Industrial Safety Gloves [Leather & Cotton Gloves]
IS: 1989 - 1986 [Part-II]	Leather Safety Boots & Shoes
IS: 5557 - 1969	Industrial & Safety Rubber Knee Boots
IS: 6519 - 1971	Code of Practice for Selections, Care & Repair of Safety Footwear
IS: 11226 - 1985	Leather Safety Footwear Having Direct Molding Sole
IS: 5983 - 1978	Eye Protectors
IS: 9167 - 1979	Ear Protectors
IS: 3521 - 1983	Industrial Safety Belts & Harnesses

Guidelines for imposition of punitive fines

- 4.0 Punitive fines on contractors are imposed for violation of safety rules & regulations during execution of jobs. Objective of punitive fines is to work as deterrent for contractors in violation of safety rules & regulation and to improve safety atmosphere in general at all site.

Proposed guidelines for imposition are described below:

- 4.1 For first time violation of safety rules & regulation by any contractor, HSE-officer will issue a warning letter to contractor with intimation to EIC of work centre with a copy to MD & DC.
- 4.2 In case of second time violation of safety rules & regulations by same contractor, EIC will call



HEALTH, SAFETY AND ENVIRONMENT [HSE] SPECIFICATIONS

contractor in person and will have a meeting to discuss reason for repetitive violation along with HSE-Officer. A warning letter will also be issued by EIC to contractor.

- 4.3 In case of further violation, punitive fines will be imposed on contractor. Amount as fine will be decided as per severity of violation of safety. However, minimum fine would be Rs.5,000/- and in multiple of Rs.5,000/-, thereafter for every instant.
- 4.4 This will be limited to 5% of contract value, as maximum cumulative penalty.
- 4.5 This practice of punitive fines is to be implemented across all CUGL sites for all contracts.
- 4.6 Practice of punitive fines will be applicable for projects sites also and would be over and above the deduction made by M/s CUGL for safety violation from running bills.



Central U.P. Gas Limited

STANDARD QUALITY ASSURANCE PLAN

Brass Fittings

SR. No	DESCRIPTION	QUANTUM OF CHECK	PROCEDURE	ACCEPTANCE CRITERIA (As per EN 1057/ PTS)	FORMAT OF RECORD	INSPECTION		REMARKS
						VENDOR	TPIA	
1	Raw material: Chemical/ Physical Requirement	one in each heat	As per EN 12164/ PTS	As per EN 12164/ PTS	MTC	P	W	
2	Final product					P	W	
2.1	Resistance dezincification	one in each heat	As per EN 6509/ PTS	As per EN 6509/ PTS	Test Report	P	W	
2.2	Carbon bore test	one in each heat	As per EN 1254/ ISO 6957/PTS	As per EN 1254/ISO 6957/ PTS	Test Report	P	W	
2.3	Stress corrosion resistance test	one in each heat	As ISO 6957	ISO6957	Test Report	P	W	
2.4	Hydrostatic pressure test	100%	As per EN 1254/EN 12164	Min 37.5 bar @ 15 min.	Test Report	P	RW	Min 10 % by TPIA
2.5	Pneumatic pressure test	100%	As per EN 1254/ EN 12164/ PTS	Min 6 bar @ 15 second	Test Report	P	RW	Min 10 % by TPIA
2.6	Visual Inspection (Free from defect)	100%	As per EN 12164/ EN 1254/PTS	As per EN 1254/ PTS	Test Report	P	RW	Min 10 % by TPIA
2.7	Dimensional Inspection (O.D, Wall thk., Length etc.)	100%	As per EN 12164/EN 1254/PTS	As per EN 1254/ PTS	Test Report	P	RW	Min 10 % by TPIA
3	Marking	100%	EN 12164/ EN 1254	As per EN 1254		P	RW	Min 10 % by TPIA

CLIENT: CENTRAL UP GAS LTD



STANDARD QUALITY ASSURANCE PLAN

Brass Fittings

4	Documentation	-	PTS	PTS	Test Report	P	H	
---	---------------	---	-----	-----	-------------	---	---	--

LEGENDS: H-HOLD

RW – RANDOM WITNESS

W-WITNESS

P-PERFORM

TPIA- THIRD PARTY INSPECTION AGENCY

MTC – MATERIAL TEST CERTIFICATE

1. The above testing and acceptance criteria are minimum requirements; however, manufacturer shall ensure that the product shall also comply to the applicable codes along with complying additional requirement of PTS.
2. The TPIA shall use this QAP for inspection against subject tender and may consider this document as approved.
3. Procedures have to be specially approved or only previously approved procedures have to be used, in case of conflict between specifications more stringent condition shall be applicable.
4. Owner/ Owner's representative including TPIA will have the right to inspect any activity of manufacturing at any time.
5. All reference Codes / Standards documents, PTS shall be arranged by vendor / supplier for reference of TPIA at the time of inspection.
6. At the time of delivery of material in stores, vendor will submit copy of all related document of inspection along with release note, dispatch clearance note & MTC.

Approved Vendor List

M/s Chandan Enterprises	M/s Paras Industries Limited
M/s Umesh enterprises	M/s Om Brass Enterprises
M/s KPC Flexi Tubes	M/s Mehta Bros, Mumbai
M/s Chokhawala Distributors –Brass Adaptor	M/s Kabsons Gas Equipment Pvt. Ltd.
M/s Fast Tech Engineers Pvt. Ltd.	

Notes: - Above Vendor List is indicative only & any other Vendors apart from as mentioned above may be accepted subject to approval by Owner based on past track record.

CLIENT: CENTRAL UP GAS LTD



STANDARD QUALITY ASSURANCE PLAN COPPER FITTINGS

SR. No	DESCRIPTION	QUANTUM OF CHECK	PROCEDURE	ACCEPTANCE CRITERIA (As per EN 1057/ PTS)	FORMAT OF RECORD	INSPECTION		REMARKS
						VENDOR	TPIA	
1	Raw material: Chemical Requirement	One in each heat	As per EN 1254/ PTS	Material grade Cu-DHP/ CW 024A Cu + Ag: Min 99.9% P: 0.0015% to 0.040%	MTC	P	R	
2	Final product: Chemical Requirement	One in each heat	As per EN 1254/ PTS		Test Report	P	W	
3	Carbon in bore tests (Carbon film test, carbon content test)	One in each heat	As per EN 1254/ISO 6957/ PTS	As per EN 1254/ISO 6957/ PTS	Test Report	P	W	
4	Stress corrosion resistance test	One in each heat	As per ISO 6957/ PTS	As per ISO 6957/ PTS	Test Report	P	W	
5	Hydrostatic pressure test	100%	As per EN 1254/ PTS	Min 37.5 bar @ 15 min.	Test Report	P	RW	MIN 10 % BY TPIA
6	Pneumatic pressure test	100%	As per EN 1254/ PTS	Min 6 bar @ 10 second	Test Report	P	RW	MIN 10 % BY TPIA
7	Dimensional Inspection (O.D, Wall thk., Min. Length of engagement etc.)	100%	As per EN 1254/ PTS	As per EN 1254/ PTS	Test Report	P	RW	MIN 10 % BY TPIA
8	Visual Inspection (Free from defect)	100%	As per EN 1254/ PTS	As per EN 1254/ PTS	Test Report	P	RW	MIN 10 % BY TPIA
9	Marking	100%	As per EN 1254/ PTS	As per EN 1254/ PTS	-	P	RW	MIN 10 % BY TPIA
10	Documentation	-	As per EN 1254/ PTS	As per EN 1254/ PTS	Inspection Report	P	R	

LEGENDS: **PTS-** PARTICULAR TECHNICAL SPECIFICATION
P-PERFORM

RW – RANDOM WITNESS **W-**WITNESS
TPIA- THIRD PARTY INSPECTION AGENCY

CLIENT: CENTRAL UP GAS LTD



STANDARD QUALITY ASSURANCE PLAN COPPER FITTINGS

1. The above testing and acceptance criteria are minimum requirements; however, manufacturer shall ensure that the product shall also comply to the applicable codes along with additional requirement of PTS.
2. The TPIA shall use this QAP for inspection against subject tender and may consider this document as approved.
3. Procedures have to be specially approved or only previously approved procedures have to be used, in case of conflict between specifications more stringent condition shall be applicable.
4. Owner/ Owner's representative including TPIA will have the right to inspect any activity of manufacturing at any time.
5. All reference Codes / Standards documents, PTS shall be arranged by vendor / supplier for reference of TPIA at the time of inspection.
6. At the time of delivery of material in stores, vendor will submit copy of all related document of inspection along with release note, dispatch clearance note & MTC.

Approved Vendor List	
M/s Rajco metal	M/s Jay Banas M/s Mehta Tubes Limited- Trade Mark "MEXFLOW"
M/s Paras Industries	M/s Mercure Metal & Alloys Pvt Ltd
M/s Chandan Enterprises	M/s Mehta Tubes
M/s Jay Banas Metals Pvt. Ltd.	

Notes: - Above Vendor List is indicative only & any other Vendors apart from as mentioned above may be accepted subject to approval by Owner based on past track record.

CLIENT: CENTRAL UP GAS LTD



QAP No.: -

**STANDARD QUALITY ASSURANCE PLAN
GI PIPES POWDER COATED CONFORMING TO IS:1239 (PART-1):2004 (Latest edition)**

S.N	COMPONENTS /OPERATIONS	CHARACHTERISTICS	CLASSIFICATION	TYPE OF CHECK	QUANTUM OF CHECK	REFERENCE DOCUMENTS	ACCEPTANCE NORMS	FORMAT OF RECORD	VENDOR	TPIA
1	2	3	4	5	6	7	8	9	10	11
1	RAW MATERIAL INSPECTION									
1.1	RAW MATERIAL (Steel tube Heavy Duty Class C)	IDENTIFICATION	Major	Co-relation with MTC.	100%	IS:1239/P.O. Spec./PTS	IS:1239/P.O. Spec./PTS	T.C.	P	R
		CHEMICAL COMPOSITION	Major	Chem. Analysis	One per Heat	IS: 1239 / P.O./ PTS	IS:1239/P.O. Spec./PTS	T.C.	P	R
		PHYSICAL PROPERTIES (T.S., Y.S., % Elongation)	Major	Lab. Test	One per Heat	IS:1239/P.O. Spec./PTS	IS:1239/P.O. Spec./PTS	T.C.	P	R
		VISUAL & DIMENSIONS	Major	Visual & Measurement	100%	IS:1239/P.O. Spec./PTS	IS:1239/P.O. Spec./PTS	T.C.	P	R
2	IN PROCESS INSPECTION									
2.1	PIPE MANUFACTURING	SURFACE DEFECT	Major	Visual	100%	IS:1239/P.O.	IS:1239/P.O. Spec./PTS	IIR	P	R
		DIMENSIONS (O.D., THK. LENGTH etc.)	Major	Measurement	SCALE OF SAMPLING FOR TESTING AS PER IS 4711:2008 TABLE NO. 1 & 2	IS:1239/P.O. Spec./PTS	IS:1239/P.O. Spec./PTS	IIR	P	R
		MASS (Kg/Mtr)	Major	Measure.		IS:1239/P.O. Spec./PTS	IS:1239/P.O. Spec./PTS	IIR	P	R
2.2	END PREPARATION	END TYPE & DIMENSIONS	Major	Visual & Measurement	SCALE OF SAMPLING FOR TESTING AS PER IS 4711:2008 TABLE NO. 1 & 2	IS:1239/P.O. Spec./PTS	IS:1239/P.O. Spec./PTS	IIR	P	R
2.3	PHYSICAL PROPERTIES	TENSILE Strength, ELONGATION & BEND Test/FLATTENING TEST AS APPLICABLE	Major	Lab. Test		IS:1239/P.O. Spec./PTS	IS:1239/P.O. Spec./PTS	IIR	P	R

CLIENT: CENTRAL UP GAS LTD



QAP No.: -

**STANDARD QUALITY ASSURANCE PLAN
GI PIPES POWDER COATED CONFORMING TO IS:1239 (PART-1):2004 (Latest edition)**

2.4	LEAK TEST	HYDRAULIC	Critical	Leak Test	100%	IS:1239/P.O. Spec./PTS	IS:1239/P.O. Spec./PTS	IIR	P	R
2.5	GALVANIZING	ZINC COATING UNIFORMITY & MASS	Major	Galv. Test (Mass of Zinc Coating & Uniformity)	ONE SAMPLE AT EVERY FOUR HOURS & AS PER IS:4736	IS: 4736	IS: 4736 & IS: 2633	IIR	P	R
2.6	FINISH, PAINTING & MARKING	OVERALL FINISH, PAINTING & MARKING	Major	Visual	100%	IS:1239/P.O. Spec./PTS	IS:1239/P.O. Spec./PTS	IIR	P	R
3	POWDER COATING TEST									
3.1	POWDER COATING TEST	SALT SPRAY RESISTANCE	Major	Visual	1000 Hrs (MIN.)	IS: 13871	IS: 13871	IIR	P	R
3.2		POROSITY	Major	Visual	-	IS: 13871	IS: 13871	IIR	P	R
3.3		HUMIDITY RESISTANCE	Major	Visual	1000 Hrs (MIN.)	IS: 13871	IS: 13871	IIR	P	R
3.4		WEATHERING GLOSS RETENTION AFTER 1000 Hrs.(Sun Test with Water Impression , Xenon 150 K lux)	Major	Visual	60 - 70%	IS: 13871	IS: 13871	IIR	P	R
3.5		COLOUR	Major	Visual	CANARY YELLOW	IS: 13871	IS: 13871	IIR	P	R
4	FINAL INSPECTION									
4.1	FINISHED	FINISH DIMENSIONS	Critical	Visual &	SCALE OF	IS:1239/P.O.	IS:1239/P.O.	Dimensional	P	W

CLIENT: CENTRAL UP GAS LTD



Central U.P. Gas Limited

QAP No.: -

**STANDARD QUALITY ASSURANCE PLAN
GI PIPES POWDER COATED CONFORMING TO IS:1239 (PART-1):2004 (Latest edition)**

	PRODUCT		Measurement.	SAMPLING AS PER IS 4711:2008 TABLE NO. 1 & 2	Spec./PTS	Spec./PTS	IR			
		PHYSICAL PROPERTIES (TENSILE STRENGTH, ELONGATION & BEND TEST/ FLATTENING TEST AS APPLICABLE)	Critical	Lab.Test	One Sample per Heat	IS:1239/P.O. Spec./PTS	IS:1239/P.O. Spec./PTS	Physical IR	P	W
		MASS OF ZINC COATING, UNIFORMITY & ADHESION TEST	Critical	GALV. TEST (LAB Test)	One Sample per Heat	IS 4736	IS 4736	GALV. REPORT	P	W
		LEAK TEST (HYDRAULIC TEST)	Critical	Leak Test	100% by MFR.	IS:1239/P.O. Spec./Tender Spec	IS:1239/P.O. Spec./Tender Spec	IR	P	RW (Min. 10% per lot by TPIA)
		REVIEW OF ALL TEST CERTIFICATE I REPORTS & VENDOR'S IIR	Major	Review	All TC	IS:1239/P.O. Spec./Tender Spec., EN 10204	IS:1239/P.O. Spec./Tender Spec., EN 10204	R	P	R
		Coating Thickness	Major	Visual	Random as per IS: 13871	IS: 13871/ PTS	IS: 13871/ PTS	IIR	P	W
4.2	POWDER COATING TEST	GLOSS 60 DEG.	Major	VISUAL	AS PER IS: 4711/ IS:13871	IS: 13871/ PTS	IS: 13871/ PTS	IR	P	W
		CROSS HATCH ADHESION	Major	VISUAL	AS PER IS: 13871	IS: 13871/ PTS	IS: 13871/ PTS	IR	P	W
		CYLINDRICAL BENDING TEST	Major	VISUAL	AS PER IS: 13871	IS: 13871/ PTS	IS: 13871/ PTS	IR	P	W
		ENRICHSEN CUPPING	Major	VISUAL	AS PER IS: 13871	IS: 13871/ PTS	IS: 13871/ PTS	IR	P	W
		PENCIL HARDNESS	Major	VISUAL	AS PER IS: 13871	IS: 13871/ PTS	IS: 13871/ PTS	IR	P	W
		SCRATCH RESISTANCE	Major	VISUAL	AS PER IS: 13871	IS: 13871/ PTS	IS: 13871/ PTS	IR	P	W
		IMPACT RESISTANCE	Major	VISUAL	AS PER IS: 13871	IS: 13871/ PTS	IS: 13871/ PTS	IR	P	W
4.3	-	IDENTIFICATION & MARKING	Major	VISUAL	IS: 4711	IS: 1239 / P.O. Spec./PTS	IS: 1239 / P.O. Spec./PTS	-	P	W
4.4	-	WORKMANSHIP	Major	VISUAL	IS: 4711	IS: 1239 / P.O. Spec./PTS	IS: 1239 / P.O. Spec./PTS	-	P	R
4.5	-	PERFORMANCE OF INSTRUMENTS	Major	CALIBERATION	EACH INSTRUMENT	IS: 1239 / P.O. Spec./PTS	IS: 1239 / P.O. Spec./PTS	CALIBRATION CERTIFICATE	P	R

LEGENDS: H-HOLD P-PERFORMANCE R-REVIEW RW – RANDOM WITNESS W-WITNESS TC-TEST CERTIFICATE IIR-INTERNAL INSPECTION REPORTIR-INSPECTION REPORT TPIA - THIRD PARTY INSPECTION AGENCY

1. The above testing and acceptance criteria are minimum requirements; however, manufacturer shall ensure that the product shall also comply to the applicable codes.

CLIENT: CENTRAL UP GAS LTD



Central U.P. Gas Limited

QAP No.: -

**STANDARD QUALITY ASSURANCE PLAN
GI PIPES POWDER COATED CONFORMING TO IS:1239 (PART-1):2004 (Latest edition)**

2. The TPIA shall use this QAP for inspection against subject tender and may consider this document as approved.
3. Mechanical & Chemical Testing shall be done in NABL Accredited Lab.
4. Procedures have to be specially approved or only previously approved procedures have to be used, in case of conflict between specifications.
5. Owner/ Owner's representative including TPIA will have the right to inspect any activity of manufacturing at any time.
6. All reference Codes / Standards documents, P.O. Copies shall be arranged by vendor / supplier for reference of TPIA at the time of inspection.
7. At the time of delivery of material in stores, vendor will submit copy of all related document of inspection along with release note, dispatch clearance note & MTC.

APPROVED VENDOR LIST FOR GI PIPE

M/s Swastik Pipe Ltd.	M/s Jindal Pipes Ltd
M/s Vishal Pipes	M/s Rama Steel Tubes
M/s Fortune Pipes Ltd.	M/s Indian Seamless Metals Tube Ltd. (Pune)
M/s Indus Tubes Ltd.	M/s Advance Steel Tubes Ltd.
M/s Good Luck Tubes Ltd.	M/s Surya Roshni Ltd.
M/s APL Apollo Tubes Ltd.	M/s P S Steel Tubes Ltd. Bhilai

Notes: - 1. Above Vendor List is indicative only & any other Vendors apart from as mentioned above may be accepted subject to approval by Owner based on past track record.

CLIENT: CENTRAL UP GAS LTD



STANDARD QUALITY ASSURANCE PLAN

GI FITTINGS

QAP:

SR. No	DESCRIPTION	COMPONENT	CHARACTERISTICS	QUANTUM OF CHECK	REFERENCE DOCUMENT	ACCEPTANCE NORMS	RECORD	INSPECTION		REMARKS
								MANUF.	TPIA	
1	Chemical composition of material	Test Bar	Marking and correlation with TC	As per IS: 14329 Grade BM 300	IS: 14329 Grade BM 300, PO, PTS, Material specification	IS 14329/ PO, PTS Material specifications	Mill T.C.	R	R	
2	Chemical composition of Final product	Fitting	Chemical properties	As per IS: 14329 Grade BM 300	IS: 14329 Grade BM 300, PO, PTS, Material specification	IS 14329, PO, PTS, Material specifications	T.C.	P	R	
3	Cleaning and Finishing	Fitting	Descaling/ Peel Off	100% by Manufacturer	IS 14329	IS 14329	Inspection Report	P	RW	As per sampling Procedure of IS 1879 Table No-29
4	Destructive Testing (Tensile, Elongation & Hardness)	Fitting	Mechanical Properties	As per IS 14329	IS 14329	IS 14329	Lab Report	P	W	
5	Compression Test	Fitting	Malleability	Three samples per Heat Treatment Batch	IS 1879	IS 1879	Inspection Report	P	W	As per sampling procedure of IS 1879
6	Pressure Test	Fitting	Pneumatic	IS 1879	IS 1879	IS 1879	Inspection Report	P	W	As per sampling procedure of IS 1879
7	Alignments of Thread	Fitting	ASME B1.20.1/NPT	IS 1879	IS 1879	IS 1879	Inspection Report	P	W	As per sampling procedure of IS 1879
8	Galvanizing	Fitting	Integrity of galvanized coating	As listed in IS 4759	IS 4759	IS 2629	Inspection / Lab Report	P	W	As per sampling procedure of IS 4759
9	Final inspection	Fitting	Visual, Dimensions, Thread Gauge	IS 1879	IS 1879	IS 1879/ PTS	Inspection Report	P	W	

CLIENT: CENTRAL UP GAS LTD



Central U.P. Gas Limited

STANDARD QUALITY ASSURANCE PLAN GI FITTINGS

QAP:

Alignment, Finish, weld
bevel, Bore, Marking,
Powder Coating
Thickness*

10	Marking	Fitting	Size, Owner & Manufacturer Logo	100%	IS 1879/PTS	IS 1879/PTS	Inspection Report	P	R
11	Documentation	-			As per the terms and conditions of the PO & PTS	As per the terms and conditions of the PO & PTS	Compliance certificate & TC	P	R

LEGENDS: - H-HOLD P-PERFORM R-REVIEW RW – RANDOM WITNESS
 W-WITNESS TC-TEST CERTIFICATE TPIA-THIRD PARTY INSPECTION AGENCY

- NOTES:
- The above testing and acceptance criteria are minimum requirements; however, manufacturer shall ensure that the product shall also comply to the applicable codes.
 - The TPIA shall use this QAP for inspection against subject tender and may consider this document as approved.
 - Mechanical & Chemical Testing shall be done in NABL Accredited Lab.
 - Procedures have to be specially approved or only previously approved procedures have to be used, in case of conflict between specifications.
 - Owner/ Owner's representative including TPIA will have the right to inspect any activity of manufacturing at any time.
 - All reference Codes / Standards documents, P.O. Copies shall be arranged by vendor / supplier for reference of TPIA / CUGL at the time of inspection.
 - At the time of delivery of material in stores, vendor will submit copy of all related document of inspection along with release note, dispatch clearance note & MTC.

Approved Vendor List

M/s Sarin Industries Ltd.	M/s Jinan Meide Casting Co. Ltd.
M/s Jupiter Metal Industries Ltd.	M/s. Green Malleable Pvt. Ltd.
M/s Jainsons Industries Ltd.	M/s Chandan Enterprises (GI Clamps & Meter Clamps)
M/s Jay Banas	M/s Industrial Valves & Components, Delhi
M/s Rajnesh Malleables Ltd., Delhi	M/s Excel Metal & Engineering Industries, Mumbai

CLIENT: CENTRAL UP GAS LTD



Central U.P. Gas Limited

STANDARD QUALITY ASSURANCE PLAN GI FITTINGS

M/s Modern Stores & Engineering Concern, Kolkata	M/s Mehta Brother & Co., Mumbai- (Make: M/s Jinan Meide Casting Co. Ltd., Japan)
M/s Chokhawala Distributors	

Notes: - 1. Above Vendor List is indicative only & any other Vendors apart from as mentioned above may be accepted subject to approval by Owner based on past track record.

CLIENT: CENTRAL UP GAS LTD



STANDARD QUALITY ASSURANCE PLAN COPPER TUBING

						INSPECTION		
SR. No	DESCRIPTION	QUANTUM OF CHECK	PROCEDURE	ACCEPTANCE CRITERIA (As per EN 1057/ PTS)	FORMAT OF RECORD	VENDOR	TPIA	REMARKS
1	Raw material: Chemical Requirement	As per EN 1057	As per EN 1057/PTS	Material grade Cu-DHP/ CW 024A Cu + Ag: Min 99.9% P: 0.0015% TO 0.040%	MTC	P	R	
2	Final product: Chemical Requirement	As per EN 1057	As per EN 1057/PTS		Inspection Report	P	W	
3	Physical test (Tensile, Elongation, Hardness etc.)	As per EN 1057	As per EN 1057/PTS	UTS- Min. 235 N/ Sq.mm Elongation - Min 30% Hardness- 75 TO 100 HV scale	Inspection Report	P	W	
4	Carbon film test	As per EN 1057	As per EN 1057/PTS	As per EN 1057/ PTS (Maximum Residual carbon- 0.20 mm/ sq. dm)	Inspection Report	P	W	
5	Carbon content test	As per EN 1057	As per EN 1057	As per EN 1057/ PTS	Inspection Report	P	W	
6	Drift expanding test	As per EN 1057	As per EN 1057	As per EN 1057/ PTS	Inspection Report	P	W	
7	Hydrostatic test	As per EN 1057	As per EN 1057	Min 35 bar/ 10 second	Inspection Report	P	RW	Min 10 % by TPIA
8	Eddy current test	As per EN 1057	As per EN 1057	As per EN 1057/ PTS	Inspection Report	P	RW	Min 10 % by TPIA
9	Dimensional Inspection (O.D, Wall thk, Length etc.)	As per EN 1057	As per EN 1057	As per EN 1057/ PTS	Inspection Report	P	RW	Min 10 % by TPIA
10	Visual Inspection (Free from defect)	As per EN 1057	As per EN 1057	As per EN 1057/ PTS	Inspection Report	P	RW	Min 10 % by TPIA
11	Marking	As per EN 1057	As per EN 1057	As per EN 1057/ PTS	Inspection Report	P	RW	Min 10 % by TPIA
12	Documentation	-	As per EN 1057	As per EN 1057/ PTS	Inspection Report	P	R	

CLIENT: CENTRAL UP GAS LTD



STANDARD QUALITY ASSURANCE PLAN COPPER TUBING

LEGENDS: - H-HOLD AGENCY RW – RANDOM WITNESS W- WITNESS P- PERFORM TPIA- THIRD PARTY INSPECTION
PTS- PARTICULAR TECHNICAL SPECIFICATION

1. The above testing and acceptance criteria are minimum requirements; however, manufacturer shall ensure that the product shall also comply to the applicable codes.
2. The TPIA shall use this QAP for inspection against subject tender and may consider this document as approved.
3. Procedures have to be specially approved or only previously approved procedures have to be used, in case of conflict between specifications.
4. Owner/ Owner's representative including TPIA will have the right to inspect any activity of manufacturing at any time.
5. All reference Codes / Standards documents, PTS shall be arranged by vendor / supplier for reference of TPIA at the time of inspection.
6. At the time of delivery of material in stores, vendor will submit copy of all related document of inspection along with release note, dispatch clearance note & MTC.

Approved Vendor List

M/s Rajco metal	M/s Jay Banas M/s Mehta Tubes Limited- Trade Mark "MEXFLOW"
M/s Paras Industries	M/s Mercure Metal & Alloys Pvt Ltd
M/s Chandan Enterprises	M/s Mehta Tubes

Notes: - Above Vendor List is indicative only & any other Vendors apart from as mentioned above may be accepted subject to approval by Owner based on past track record.



STANDARD QUALITY ASSURANCE PLAN MDPE Ball Valve PE 100 (Without Stem)

QAP NO:

SL No.	Test Description	Type Of Check	Quantum Of Check	Ref. Document	Acceptance Norms	Format of Records	Inspection		Remarks
							Vendor	TPIA	
1	Raw Materials	Test Certificate for Raw Materials	Each Batch	EN 1555-1/PTS	EN 1555-1/PTS	MTR	P	R	
2	Test of raw material inspection	Raw Material Characteristics Check	Each Batch	Test Certificate for Raw Materials	As per material test cert.	MTR	P	R	
3	Hydrostatic Strength (PE100) (At 20 °c and 80 °c)	Strength Test	100%	EN 1555- 4 & ISO 1167-1/4/PTS	As per EN 1555- 4 & ISO 1167-1/4/PTS (No failure and no leak during test period of any test piece)	Hydrotest Report	P	W	
4	Leak Tightness test	Mechanical Characteristics	100%	EN 1555- 4/PTS	As per Table-1, EN 1555-4/ PTS (No Leakage)	MTR	P	W	
5	Operating Torque	Mechanical Characteristics	100%	EN 1555- 4/PTS	As per Table-1, EN 1555-4/EN28233/ PTS	MTR	P	R	

CLIENT: CENTRAL UP GAS LTD



STANDARD QUALITY ASSURANCE PLAN MDPE Ball Valve PE 100 (Without Stem)

QAP NO:

6	Pressure Drop.	Mechanical Characteristics (Air flow rate)	Each Batch	ISO 17778/ EN 1555-3/ PTS	ISO 17778/ EN 1555-3/ PTS	IR	P	R	
7	Oxidation Induction Time (Thermal Stability)	Physical Characteristics	Each Batch	EN 1555-3/ EN 728/ ISO 11357-6/ PTS	As per EN 1555-3/ EN 728/ ISO 11357-6/ PTS	MTR	P	R	
8	Melt mass flow Rate	Physical Characteristics	Each Batch	EN 1553-3/ EN ISO 1133/ PTS	As per EN 1553-3/ EN ISO 1133/ PTS	MTR	P	R	
9	Dimensional Check	Dimensions	Each Batch	EN 1555-3/PTS	As per EN 1555-3/ PTS	IR	P	RW	Min. 10 % by TPIA
10	Density	Physical Characteristics	100%	ISO 1183/PTS	0.926 to 0.94 g/cm ³	MTR	P	R	
11	Volatile Content	Physical Characteristics		EN 12099/PTS	≤350mg/Kg	MTR	P	R	
12	Content Carbon Black	Physical Characteristics		ISO 6964/PTS	2.50 ± 0.5%	MTR	P	R	
13	Appearance, Color	General Characteristics	100%	EN 1555-4/PTS	EN 1555- 4/PTS	IR	P	R	

CLIENT: CENTRAL UP GAS LTD



STANDARD QUALITY ASSURANCE PLAN MDPE Ball Valve PE 100 (Without Stem)

QAP NO:

14	Marking	Physical Characteristics	100%	EN 1555- 3/ PTS	EN 1555- 3/ PTS	IR	P	RW	Min. 10 % by TPIA
15	Lot Release test		Each Lot	EN 1555- 7/PTS	EN 1555-7/PTS	IR	P	RW	
	Note:								
1	The above testing and acceptance criteria are minimum requirements; however, manufacturer shall ensure that the product shall also comply to the additional requirements as per PTS/ SS.								
2	The TPIA shall use this QAP for inspection against subject tender and may consider this document as approved.								
3	Special manufacturing procedures have to be specially approved or only previously approved procedures have to be used, in case of conflict between specifications more stringent condition shall be applicable.								
4	Owner / Owner's representative including TPIA will have the right to inspect any activity of manufacturing at any time.								
5	All reference Codes/ Standards, Documents, P.O. Copies shall be arranged by vendor / supplier for reference of TPIA at the time of Inspection								
6	At the time of delivery of material in stores, vendor will submit copy of all related document of inspection along with release note & MTC.								
	Legends:								
	R Review P Perform	H Hold W Witness	TPIA Third Party Inspection Agency MTR Material Test Report	PTS Particular Technical Specification SS Standard Specification					

CLIENT: CENTRAL UP GAS LTD



STANDARD QUALITY ASSURANCE PLAN MDPE Ball Valve PE 100 (Without Stem)

Approved Vendor list	
M/s Gorge Fischer Piping Systems Pvt. Ltd.	M/s Kimplas Piping Systems Ltd.
M/s Glynwed Pipe Systems (I) Pvt. Ltd.	M/s Aliaxis Utilities & Industry Pvt. Ltd.
M/s AVK Valves India Pvt. Ltd.	M/s Tega Muhendislik San Tic
M/s Jain Irrigation Pvt. Ltd., Jalagon	M/s Friatech AG, Germany (represented by M/s Sherman Sales in India)
M/s RMG Autometers Gas Technologies	M/s Innogaz & M/s Frialen of M/s Aliaxis Utilities & Industry Pvt. Ltd.
Note: - Above Vendor List is indicative only & any other Vendors apart from as mentioned above may be accepted subject to approval by Owner based on past track record.	

CLIENT: CENTRAL UP GAS LTD

QAP No:

STANDARD QUALITY ASSURANCE PLAN

Electrofusion Fittings and Transition Fittings



Date:

Sr. No.	Test Description	Type of Check	Quantum of Check	Ref. Document	Acceptance Norms	Format of Record	Inspection		Remarks
							Mfg.	TPIA	
1	Raw Material	Review of test certificate		EN 1555-1/ PTS	EN 1555-1/ PTS	MTR	P	R	
2	Hydrostatic Strength (PE100) (At 20 °C and 80 °C)	Strength Test	As per EN 1555-7	EN 1555-3 / ISO 1167 / PTS	As per EN 1555-3 / ISO 1167 / PTS (No failure and no leak during test period of any test piece)	Hydro test Report	P	W	
3	Decohesive resistance for Electrofusion Socket fittings	Length of initiation of rupture \leq L2/3 in brittle failure	As per EN 1555-7	ISO 13954 / ISO 13955/ PTS	As per EN 1555-3	IR	P	R	
4	Decohesive Strength for Electrofusion Saddle fittings	Surface of rupture \leq 25% brittle failure	As per EN 1555-7	ISO 13956 / PTS	As per EN 1555-3	IR	P	R	
5	Impact Resistance for Electrofusion Saddle fittings	Mechanical Properties	As per EN 1555-7	EN 1716/PTS	EN 1716/PTS	IR	P	R	
5	Tensile Strength for butt fusion	Mechanical Properties	As per EN 1555-7	ISO DS 13953 / PTS	ISO DS 13953 / PTS	IR	P	R	Applicable for spigot end fittings
6	Pressure Drop.	Mechanical Characteristics	As per EN 1555-7	ISO 17778 / EN 12117/	EN 12117/ EN 1555-3	IR	P	R	

QAP No:



STANDARD QUALITY ASSURANCE PLAN

Electrofusion Fittings and Transition Fittings

Date:

		(Air flow rate)		PTS					
7	Electrical Resistance Test	Electrical Characteristics	As per EN 1555-7	EN 1555-3	EN 1555-3	IR	P	R	
8	Oxidation Induction Time (Thermal Stability)	Physical Characteristics	As per EN 1555-7	EN 1555-3/ EN 728/ ISO 11357-6/ PTS	OIT > 20 Min./ 200°C	MTR	P	R	—
9	Melt mass flow rate (MFR)	Physical Characteristics	As per EN 1555-7	EN 1553-3/ EN ISO 1133/ PTS	MFR 190°/5kg. 0.20 - 1.20 gm./10 min. and after processing maximum deviation of ± 20% of the value measured on the batch used to manufacture the fitting	MTR	P	R	
10	Density	Physical Characteristics	100%	ISO 1183	0.926 to 0.94 g/cm ³	MTR	P	R	
11	Dimensional check	Dimensions	100%	As per EN 1555-3/PTS	As per EN 1555-3/PTS	IR	P	RW	Min. 10% by TPIA
12	Appearance, Color	Visual	100%	EN 1555- 3/ PTS	EN 1555- 3/ PTS	MTR	P	R	
13	Marking	Physical Characteristics	100%	EN 1555- 3/ PTS	EN 1555-3 / PTS	IR	P	RW	Min. 10% by TPIA
14	Documentation	All Inspection Reports and Certificates	-	EN 1555	All Inspection Reports and Certificates	IR	P	R	

QAP No:



STANDARD QUALITY ASSURANCE PLAN **Electrofusion Fittings and Transition Fittings**

Date:

Note:

1. The above testing and acceptance criteria are minimum requirements; however, manufacturer shall ensure that the product shall also comply to the additional requirements as per SS/ PTS along with applicable Codes & Standards.
2. The TPIA shall use this QAP for inspection against subject tender and may consider this document as approved.
3. Procedures have to be specially approved or only previously approved procedures have to be used, in case of conflict between specifications more stringent condition shall be applicable.
4. Owner/ Owner's representative including TPIA will have the right to inspect any activity of manufacturing at any time.
5. All reference Codes / Standards documents, P.O. Copies shall be arranged by vendor / supplier for reference of TPIA at the time of inspection.
6. At the time of delivery of material in stores, vendor will submit copy of all related document of inspection along with release note, dispatch clearance note & MTC.

LEGENDS:

M – Monitor

R – Review

IR – Inspection Report

TPIA – Third Party Inspection Agency

P – Perform

W – Witness

MTR – Manufacturer test certificate

PTS – Particular Technical Specification

SS – Standard Specification

Approved Vendor List

M/s AVK Valves India Pvt. Ltd.	M/s Tega Muhendislik San Tic
M/s Georg Fischer Piping Systems Pvt. Ltd.	M/s Kimplas Piping Systems Ltd.
M/s Glynwed Pipe Systems (I) Pvt. Ltd.	M/s Aliaxis Utilities & Industry Pvt. Ltd.
M/s Jain Irrigation Pvt. Ltd., Jalagon	M/s Friatech AG, Germany (represented by M/s Sherman Sales in India)
M/s RMG Autometers Gas Technologies	M/s Innogaz & M/s Frialen of M/s Aliaxis



Central U.P. Gas Limited

STANDARD QUALITY ASSURANCE PLAN WARNING MAT

QAP. No.:

S. No.	Name of test Ref. to test Standards	Type of Check/ Method	Quantum of Check	Ref. document	Acceptance Norms	Format Of Record	Vendor	TPIA	Remarks
Test on Warning Mat:									
1	Raw Material	Review of T.C.	Each Batch	IS 10889/ PTS	IS 10889/ PTS	MTR	R	R	
2	Dimension & Tolerance Width & Thickness	Measurement	Four Samples From Each Lot / Batch	PTS	As per PTS Width:300mm_+5mm Thick:1mm(minimum)	TEST REPORT	P	W	
2	Material Identification by chemical method.	Measurement	One Samples To be tested from each Lot	Perform at Alekh Plastic Testing Centre (APTC) Ahmedabad	Test sample shall be tested & to be Confirmed PE / HDPE	T.C	W	R	
3	Colour of Mat	Visual	Four Samples To be tested from each Lot	PTS/ EN 12613 / EN ISO 175	No discolouration or change of initial colour of test sample after test	TEST REPORT	W	W	
4	Test legend printing on Mat	Visual	Four Samples To be tested from each Lot.	PTS	Red colour. Ink shall not be Removed	TEST REPORT	W	W	
5	Tensile strength at break	Measurement	Four samples from each lot.	PTS	Min. 200 kg/cm ²	TEST REPORT	P	W	
6	Test of Virginity	Measurement	Four Samples	PTS	As PTS	TEST	P	W	



Central U.P. Gas Limited

STANDARD QUALITY ASSURANCE PLAN WARNING MAT

QAP. No.:

			To be tested from each Lot.			REPORT			
7	Colour Fastness test after 15 day at 15° C in 20% Ammonium sulphite solution.	Review of TC	(Type Test)	Performed at APTC Lab/NABL Lab	Satisfactory, while comparing the test specimen with a sample specimen in cool light.	T.C	R	R	
8	Colour Fastness test for 24 Hrs	Review of TC	Four Sample per Lot	PTS	No Colour change by immersion in 10 % nitric acid solution by mass	TC	P	W	
9	Colour Fastness test for 24 Hrs	Review of TC	Four Sample per Lot	PTS	No Colour change by immersion in 20 % sodium carbonate solution by mass	TC	P	W	
10	Colour Fastness test for 24 Hrs	Review of TC	Four Sample per Lot	PTS	No Colour change by immersion in 20 % ammonium sulphide solution by mass	TC	P	W	
11	Performance of printing stability	Visual	Four samples from each lot. Lot.	PTS/ EN 12613	Pass. Marking shall be easily Legible after the test	TEST REPORT	P	W	
12	Visual Warning Characteristics	Visual	Four samples from each lot. Lot.	PTS/ EN 12613	As per EN 12613	IR	P	W	
13	Anti-Rodent Test Non-Toxic, Non-Hazardous, Non-Biodegradable	Review of TC	Type Test	Testing at any independent Laboratory	5 days / 30 days' attack test should pass. Document /certificate issued by supplier for anti-Rodent master batch as per PTS-	T.C	R	R	

CLIENT: CENTRAL UP GAS LTD



Central U.P. Gas Limited

**STANDARD QUALITY ASSURANCE PLAN
WARNING MAT**

QAP. No.:

					Toxicology data, RoHS Compliance & Non-biocidal product				
14	Colour	Each	PTS	As per PTS	Bright Yellow Colour	IR	P	W	
15	Identification, Marking Art Work & Packing	Visual	Three samples from each Lot.	PTS	Client logo- Followed by client name, Warning Symbols with Safety Message & Telephone Symbol with Contact nos. in English & local language at defined interval. Approved art work enclosed. Each roll of 50± 0.10 meter long be packed in plastic woven sack. lot/Batch No. to be printed every 1-meter Interval for identification purpose.	TEST REPORT	W	W	
16	Documentation			PTS	PTS	Compliance Certificate			



**STANDARD QUALITY ASSURANCE PLAN
WARNING MAT**

QAP. No.:

LEGENDS: R - Review, W - Witness (Give due notice work may proceed after scheduled date), TC - Test Certificate, IR - Inspection Report, P - Perform, TPIA - Third Party Inspection Agency, PTS - Particular Technical Specifications

Notes: -

1. The above testing and acceptance criteria are minimum requirements; however, manufacturer shall ensure that the product shall also comply to the applicable codes along with additional requirement of PTS.
2. The TPIA shall use this QAP for inspection against subject tender and may consider this document as approved.
3. Procedures have to be specially approved or only previously approved procedures have to be used, in case of conflict between specifications.
4. Owner/ Owner's representative including TPIA will have the right to inspect any activity of manufacturing at any time.
5. All reference Codes / Standards documents, PTS shall be arranged by vendor / supplier for reference of TPIA at the time of inspection.
6. At the time of delivery of material in stores, vendor will submit copy of all related document of inspection along with release note, dispatch clearance note & MTC.

Approved Vendor List

7. M/s Singhal Industries, Ahmedabad	8. M/s Bina Enterprises, Mumbai
9. M/s Shree Vijay Wire & Cable Industries	10. M/s Puja Packing, Mumbai
11. M/s Sparco Multiplast Pvt. Ltd.	12. M/s Raychem RPG Ltd.

Notes: - Above Vendor List is indicative only & any other Vendors apart from as mentioned above may be accepted subject to approval by Owner based on past track record.

APPROVED VENDOR LIST

APPROVED VENDOR LIST

APPROVED VENDOR LIST

ITEM CODE / DESCRIPTION	GI Pipe
VENDOR NAME	Remark
M/s Swastik Pipe Ltd.	
M/s Jindal Industries Ltd.	
M/s Vishal Pipes Ltd.	
M/s Indus Tubes Ltd	
M/s Advance steel Tubes Ltd.	
M/s Good Luck Tubes Ltd.	
M/s Surya Roshni Limited	
M/s. APL Apollo Tubes Limited	
M/s. Jindal Pipes Limited	

APPROVED VENDOR LIST

ITEM CODE / DESCRIPTION	GI fittings
VENDOR NAME	REMARKS
M/s Sarin Industries Ltd.	
M/s Jupiter Metal Industries Ltd.	
M/s Jainsons Industries Ltd.	
M/s Jinan Meide Casting Co. Ltd.	
M/s. Green Malleable Pvt. Ltd.	
M/s Chandan Enterprises(GI Clamps & Meter Clamps)	
M/s Jay Banas	
ITEM CODE / DESCRIPTION	Copper tubes & Fittings
VENDOR NAME	REMARKS
M/s Rajco metal	
M/s Jay Banas M/s Mehta Tubes Limited- Trade Mark "MEXFLOW"	
M/s.Paras Industries	
M/S Mercure Metal & Alloys Pvt Ltd	
M/s Chandan Enterprises	
ITEM CODE / DESCRIPTION	Brass Fittings
VENDOR NAME	REMARKS
M/s Chandan Enterprises	
M/s Paras Industries Ltd.	

APPROVED VENDOR LIST

M/s. Chokhawala Distributors –Brass Adaptor.	
M/s Kabsons Gas Equipment Pvt. Ltd.	
M/s Fast Tech Engineers Pvt. Ltd.	
ITEM CODE / DESCRIPTION	Steel Re-inforced Rubber Hose(Type-4)
VENDOR NAME	REMARKS
M/s Super Seal Flexible Hose Ltd.	
M/s Suraksha Products Pvt. Ltd.	
M/s Vansh Industries	
M/s T & L Gases	
ITEM CODE / DESCRIPTION	Warning Mat
VENDOR NAME	REMARKS
M/s Sparco Multiplast Pvt. Ltd.,	
M/s Singhal Industries , Ahemdabad	
M/s Puja Packing, Mumbai	
M/s Bina Enterprises, Mumbai	
M/s Shree Vijay Wire & Cable Industries	
ITEM CODE / DESCRIPTION	HDPE PIPES/DUCT
VENDOR NAME	REMARKS
M/s Climax Synthetics (P) Ltd., Vadodra	
M/s Indian Poly Pipes, Calcutta	
M/s Jain Irrigation Systems Ltd., Jalgaon	
M/s Kirti Industries (India) Ltd., Indore	
M/s Ori Plast Limited, Calcutta	
M/s Phoel Industries Limited, Delhi	
M/s Sangir Plastics (P) Ltd., Mumbai	
M/s Veekay Plast,Jaipur	
M/s Kisan Irrigation	
M/s Dutron Polymers Ltd.	
M/s Manikya Plastichem (P) Ltd	
M/s Himalyan Pipe Industries	
M/s Vishakha Irrigation Pvt. Ltd.	

APPROVED VENDOR LIST

M/s Hari Plast	
ITEM CODE / DESCRIPTION	Corrugated Flexible Metal Hoses (Anaconda)
VENDOR NAME	REMARKS
M/s KPC Flex Tubes	
M/s Vestas Hose Division	
M/s Alpha Flexi Tubes	
M/s Chandan Enterprises	
ITEM CODE / DESCRIPTION	PE(Fittings & Valves)
VENDOR NAME	REMARKS
M/s AVK Valves India Pvt. Ltd.	
M/s TEGA MUHENDISLIK SAN TIC	
M/s GEORG FISCHER PIPING SYSTEMS PVT. LTD.	
M/s KIMPLAS PIPING SYSTEMS LTD.	
M/s GLYNWED PIPE SYSTEMS (I) PVT. LTD.	
M/s Aliaxis Utilities & Industry Pvt. Ltd.	
ITEM CODE / DESCRIPTION	Isolation & Appliance Valve
VENDOR NAME	REMARKS
M/s Enologas Bonomi S.P.A	
M/s Ningbo Zhiqing industrial Co Ltd.	
M/s Chandan Enterprises	
M/s Jainsons Industries	
M/s Inkal Ventures Pvt. Ltd.	