

	TECHNICAL TENDER	
--	-------------------------	--



**CENTRAL UP GAS LIMITED
(CITY GAS PROJECT IN KANPUR & BAREILLY)**

TENDER FOR

**RATE CONTRACT AND EMPANELMENT OF CONTRACTORS FOR
LAYING OF MDPE PIPE AND ASSOCIATED WORKS FOR CITY GAS
DISTRIBUTION PROJECT AT KANPUR, UNNAO, BAREILLY &
JHANSI GA**

TENDER ID : 55272

TENDER NO. CUGL/C&P/TEN2324/38

**TECHNICAL VOLUME
(Volume II of II Part II OF II)**

**OPEN DOMESTIC COMPETITIVE BIDDING
(THROUGH E-TENDERING MODE)**

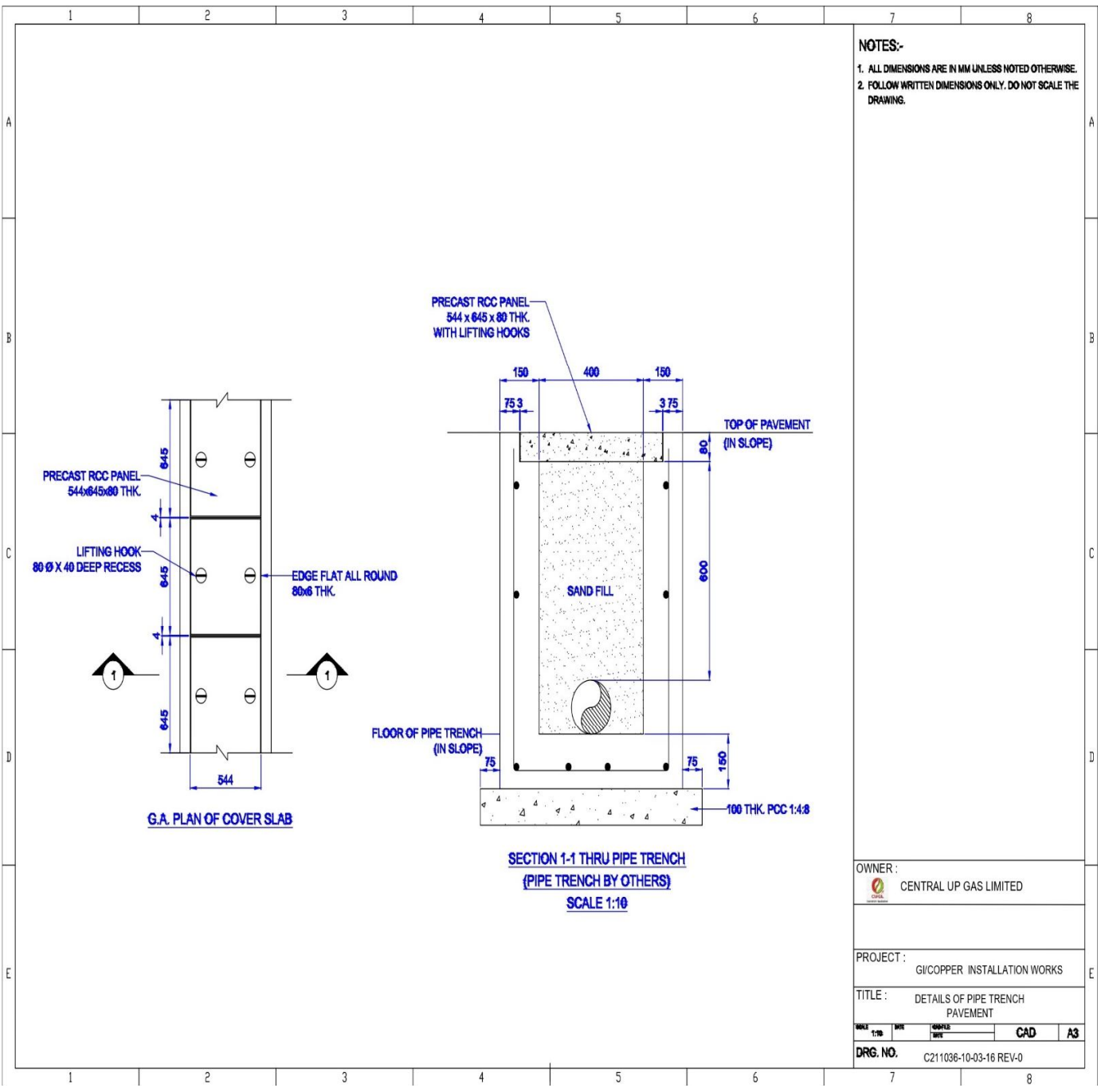

NOTES:-
1. ALL DIMENSIONS ARE IN MM UNLESS NOTED OTHERWISE.
2. FOLLOW WRITTEN DIMENSIONS ONLY. DO NOT SCALE THE DRAWING.

OWNER :		CENTRAL UP GAS LIMITED	
PROJECT :		GI/COPPER INSTALLATION WORKS	
TITLE :		DETAILS OF PIPE TRENCH PAVEMENT	
SCALE	DATE	CAD	A3
DRG. NO.	C211036-10-03-16 REV-0		

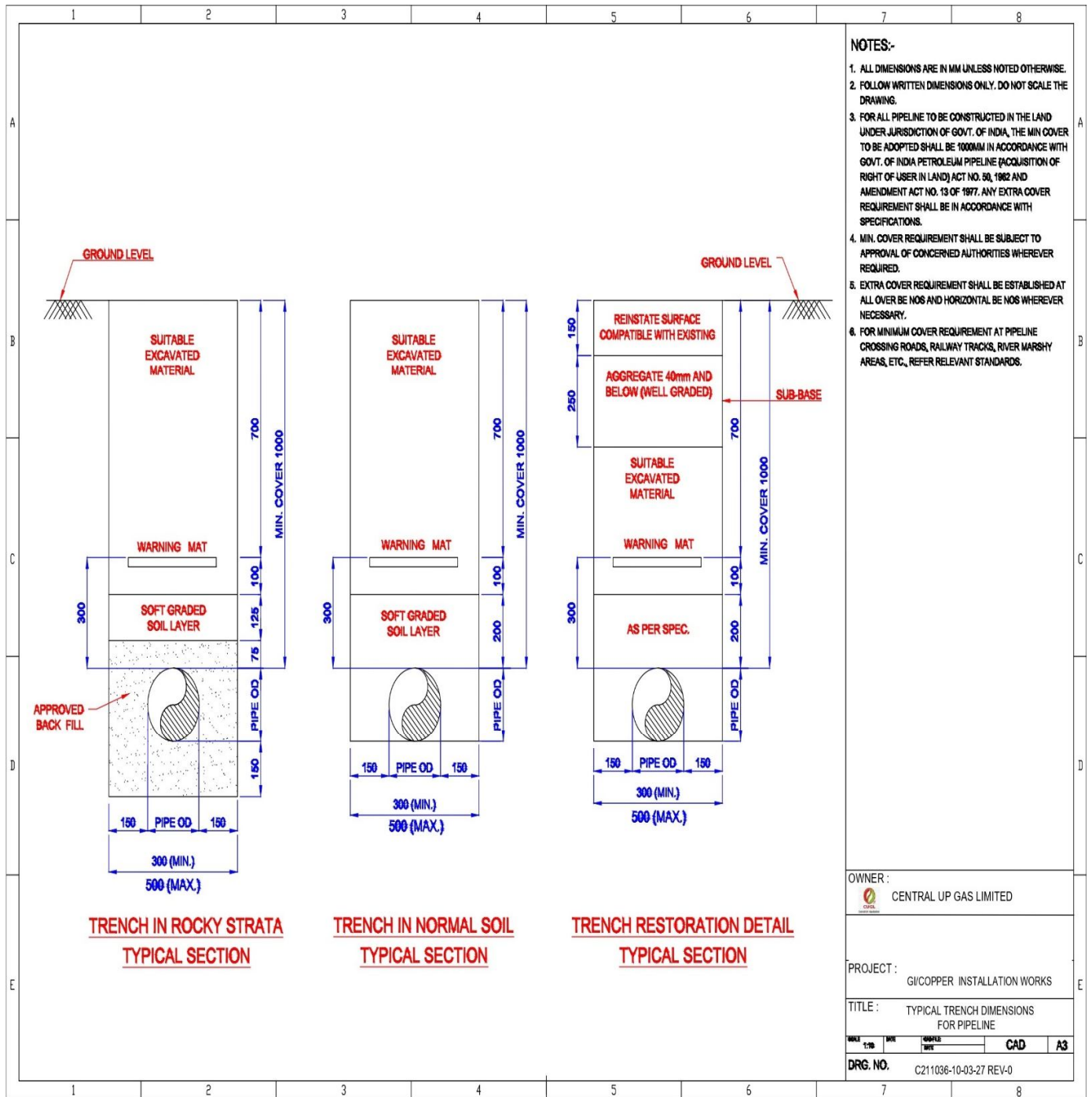

NOTES:-

1. ALL DIMENSIONS ARE IN MM UNLESS NOTED OTHERWISE.
2. FOLLOW WRITTEN DIMENSIONS ONLY. DO NOT SCALE THE DRAWING.
3. FOR ALL PIPELINE TO BE CONSTRUCTED IN THE LAND UNDER JURISDICTION OF GOVT. OF INDIA, THE MIN COVER TO BE ADOPTED SHALL BE 1000MM IN ACCORDANCE WITH GOVT. OF INDIA PETROLEUM PIPELINE (ACQUISITION OF RIGHT OF USER IN LAND) ACT NO. 50, 1962 AND AMENDMENT ACT NO. 13 OF 1977. ANY EXTRA COVER REQUIREMENT SHALL BE IN ACCORDANCE WITH SPECIFICATIONS.
4. MIN. COVER REQUIREMENT SHALL BE SUBJECT TO APPROVAL OF CONCERNED AUTHORITIES WHEREVER REQUIRED.
5. EXTRA COVER REQUIREMENT SHALL BE ESTABLISHED AT ALL OVER BE NOS AND HORIZONTAL BE NOS WHEREVER NECESSARY.
6. FOR MINIMUM COVER REQUIREMENT AT PIPELINE CROSSING ROADS, RAILWAY TRACKS, RIVER MARSHY AREAS, ETC., REFER RELEVANT STANDARDS.

OWNER :		CENTRAL UP GAS LIMITED	
PROJECT :		GICOPPER INSTALLATION WORKS	
TITLE :		TYPICAL TRENCH DIMENSIONS FOR PIPELINE	
SCALE :	DATE :	DRW. NO. :	CAD A3
DRG. NO. :	C211036-10-03-27 REV-0		

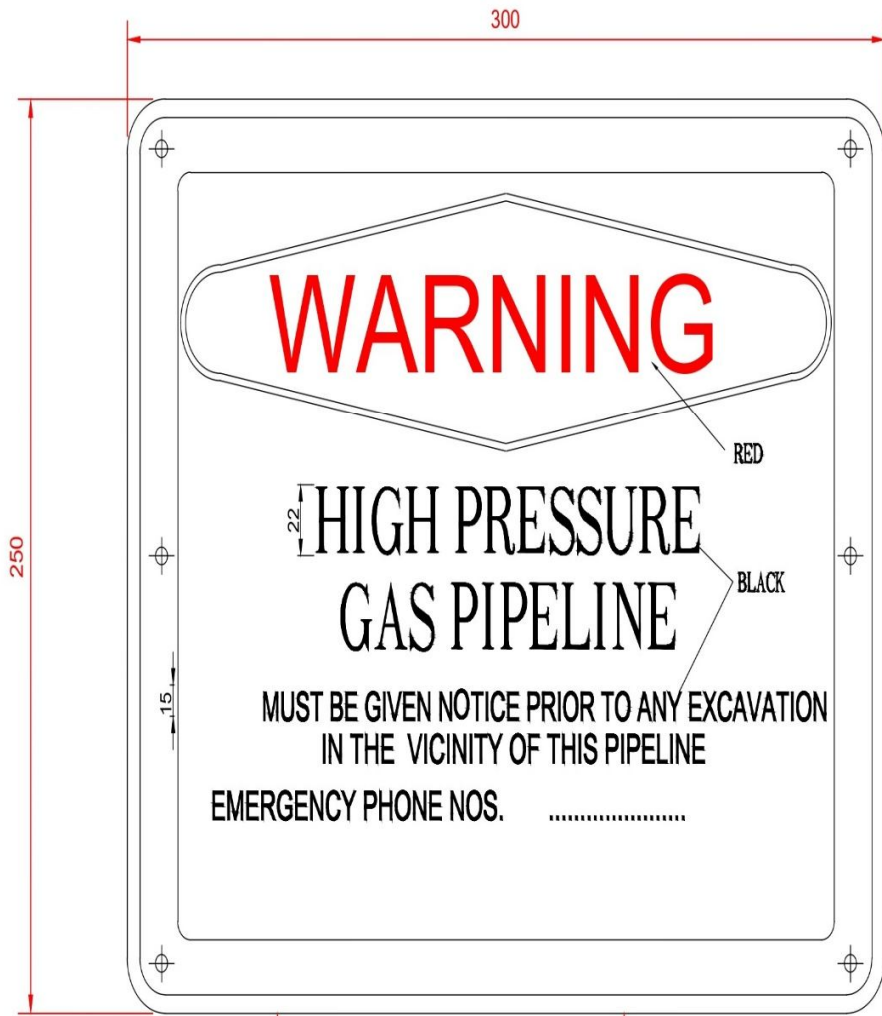

M.S PLATE 3.0 MM (MIN) THK.

POWDER COATED GOLDEN YELLOW

NOTES:-

1. ALL DIMENSIONS ARE IN MM UNLESS OTHERWISE SPECIFIED.
2. FOLLOW WRITTEN DIMENSIONS ONLY DO NOT SCALE.

CLIENT:			
		CENTRAL UP GAS LIMITED	
PROJECT:			
GI/COPPER INSTALLATION WORKS			
TITLE			
PLATE MARKER			
SCALE: NTS	CAD FILE: DATE	CAD DATE	A3
DRG. NO. 1007-10-03-28 REV-0			

1 2 3 4 5 6 7 8

A

B

C

D

E

A

B

C

D

E

- NOTES:-**
1. ALL DIMENSIONS ARE IN MM UNLESS NOTED OTHERWISE.
 2. FOLLOW WRITTEN DIMENSIONS ONLY. DO NOT SCALE THE DRAWING.
 3. ALL TEXT SHOULD BE WRITTEN IN BLACK COLOR.

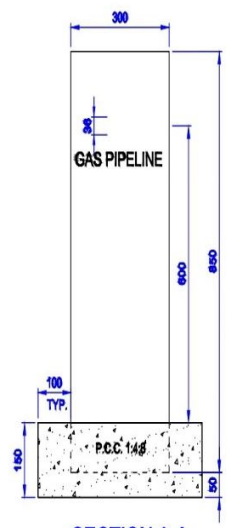

SECTION A-A

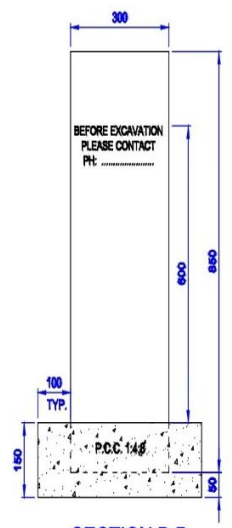

SECTION B-B

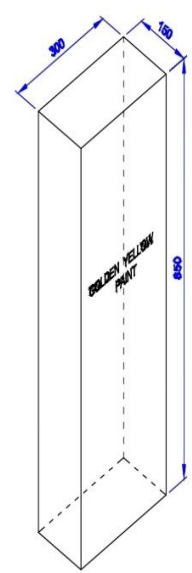

ISOMETRIC VIEW

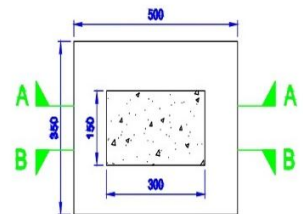

PLAIN VIEW

1 2 3 4 5 6 7 8

OWNER :
 CENTRAL UP GAS LIMITED

PROJECT :
 GI/COPPER INSTALLATION WORKS

TITLE :
 SKETCH FOR STONE MARKER

SCALE : 1:50
 DATE :
 DRAWN BY :
 CHECKED BY :
 CAD : A3

DRG. NO. : C211036-10-03-29 REV-0

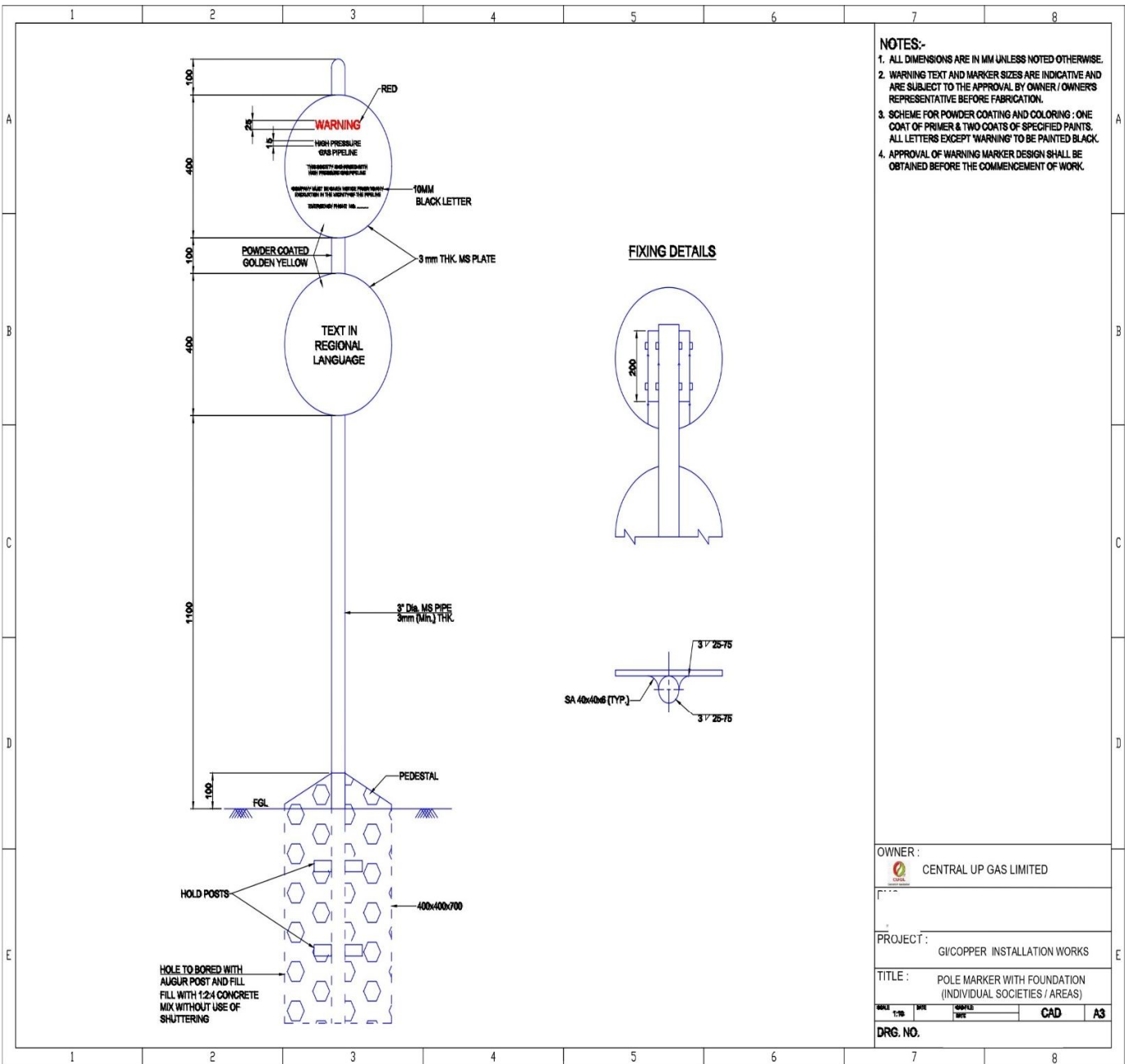

- NOTES:-**
1. ALL DIMENSIONS ARE IN MM UNLESS NOTED OTHERWISE.
 2. WARNING TEXT AND MARKER SIZES ARE INDICATIVE AND ARE SUBJECT TO THE APPROVAL BY OWNER / OWNER'S REPRESENTATIVE BEFORE FABRICATION.
 3. SCHEME FOR POWDER COATING AND COLORING : ONE COAT OF PRIMER & TWO COATS OF SPECIFIED PAINTS. ALL LETTERS EXCEPT 'WARNING' TO BE PAINTED BLACK.
 4. APPROVAL OF WARNING MARKER DESIGN SHALL BE OBTAINED BEFORE THE COMMENCEMENT OF WORK.

FIXING DETAILS

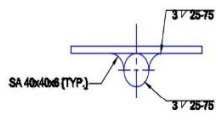
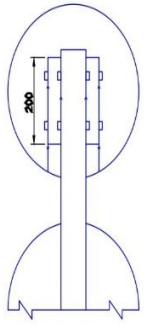

OWNER :		CENTRAL UP GAS LIMITED	
PROJECT :		GI/COPPER INSTALLATION WORKS	
TITLE :		POLE MARKER WITH FOUNDATION (INDIVIDUAL SOCIETIES / AREAS)	
SCALE	DATE	DRAWN BY	CAD
1:75			A3
DRG. NO.			

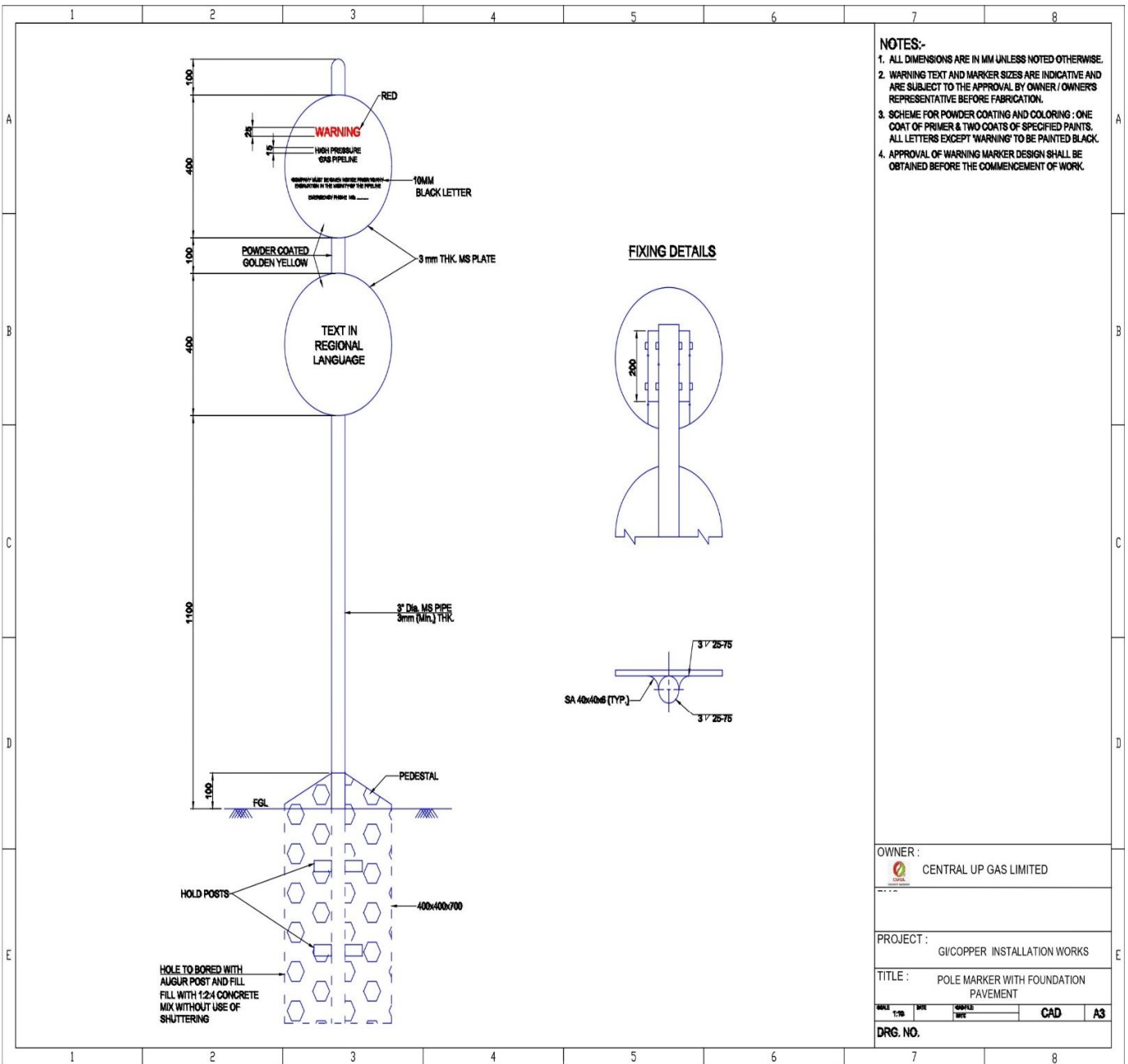

- NOTES:-**
1. ALL DIMENSIONS ARE IN MM UNLESS NOTED OTHERWISE.
 2. WARNING TEXT AND MARKER SIZES ARE INDICATIVE AND ARE SUBJECT TO THE APPROVAL BY OWNER / OWNER'S REPRESENTATIVE BEFORE FABRICATION.
 3. SCHEME FOR POWDER COATING AND COLORING : ONE COAT OF PRIMER & TWO COATS OF SPECIFIED PAINTS. ALL LETTERS EXCEPT 'WARNING' TO BE PAINTED BLACK.
 4. APPROVAL OF WARNING MARKER DESIGN SHALL BE OBTAINED BEFORE THE COMMENCEMENT OF WORK.

OWNER :	 CENTRAL UP GAS LIMITED
PROJECT :	GI/COPPER INSTALLATION WORKS
TITLE :	POLE MARKER WITH FOUNDATION PAVEMENT
SCALE :	1:10
DRG. NO.	CAD A3

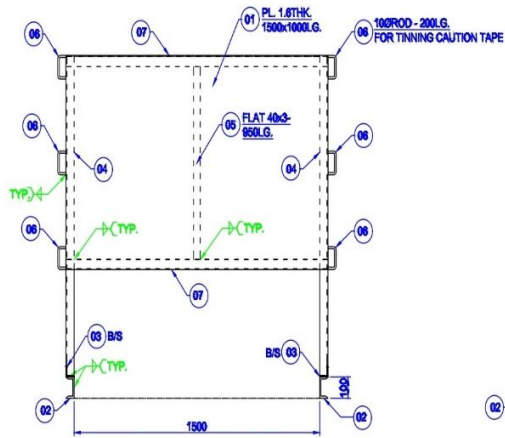

ELEVATION A-A

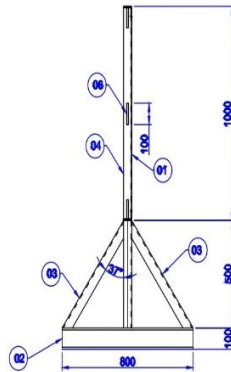

ELEVATION B-B

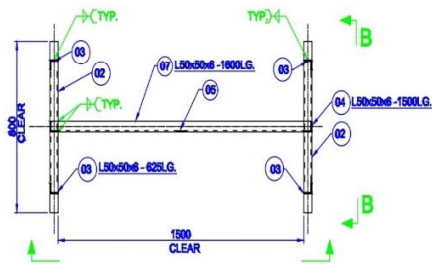

PLAN VIEW

IN RED → **CAUTION** ← CLIENT LOGO

WORK IN PROGRESS

LAYING OF NATURAL GAS PIPELINE
 CLIENT : OWNER'S NAME
 CONTRACTOR NAME:
 DATE OF COMMENCEMENT:
 DATE OF COMPLETION:
 EMERGENCY PHONE NO.:

IN BLACK

TO BE PRINTED ON ITEM NO. 01

NOTES:-

1. ALL DIMENSIONS ARE IN MM UNLESS NOTED OTHERWISE.
2. FOLLOW WRITTEN DIMENSIONS ONLY. DO NOT SCALE THE DRAWINGS.

BILL OF MATERIAL

Item	Section	Width	Length	Item Qty.	Weight	Total Weight
				(All Items)	(Kgs./MTR)	(In Kgs.)
1.	PL-1.6 THK	1800	1000	1	12.58	20.10
2.	ISMC 100	-	800	2	9.20	14.72
3.	L50x50x6	-	825	4	4.50	11.25
4.	L50x50x6	-	1500	2	4.50	13.50
5.	Flat 3THK	900	40	1	0.94	0.03
6.	100 Rod	-	200	6	0.82	0.74
7.	L50x50x6	-	1600	2	4.50	14.40
Grand Total (Kgs)						74.74

OWNER :



CENTRAL UP GAS LIMITED

PROJECT :

GI/COPPER INSTALLATION WORKS

TITLE :

CAUTION BOARD

DRG. NO.

CAD A3

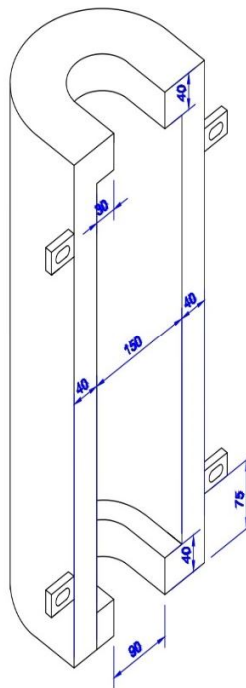
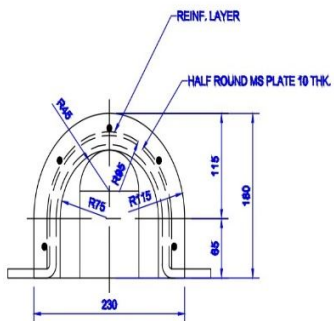

ISOMETRIC VIEW

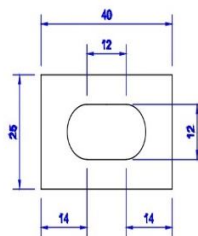
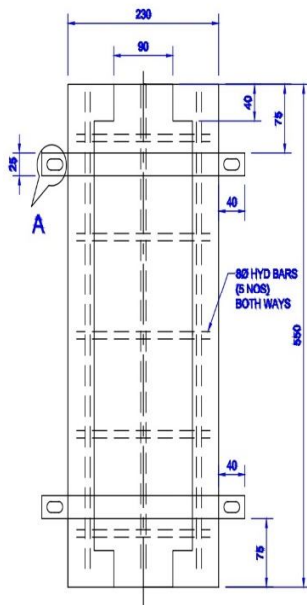

DETAIL-A
SCALE 1:1

NOTES:-

1. ALL DIMENSIONS ARE IN MM UNLESS NOTED OTHERWISE.
2. FOLLOW WRITTEN DIMENSIONS ONLY. DO NOT SCALE THE DRAWING.
3. GRADE OF CONCRETE SHALL BE M25.
4. REINFORCEMENT IS HYD. TO IS:1786.
5. CONCRETE SLEEVE TO BE CLAMPED TO WALL WITH 100 ANCHOR BOLTS.

OWNER :
 CENTRAL UP GAS LIMITED

PROJECT :
GI/COPPER INSTALLATION WORKS

TITLE :
HALF ROUND CONCRETE SLEEVE

SCALE	DATE	APPRE	DATE	CAD	A3
1:100					

DRG. NO.

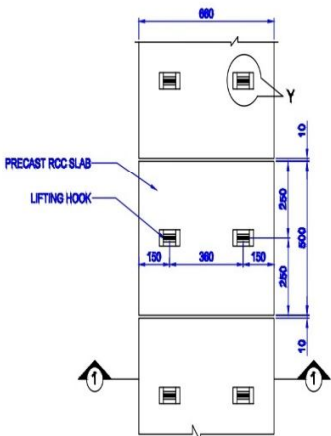

G.A PLAN OF COVER SLAB

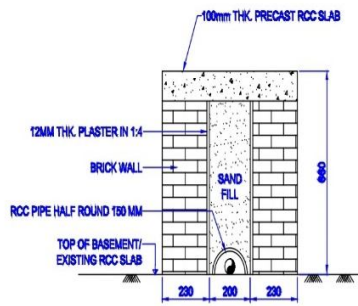

SECTION 1-1 THRU PIPE TRENCH

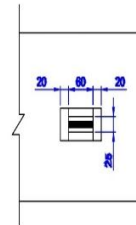

**DETAIL - Y
SCALE 1:8**

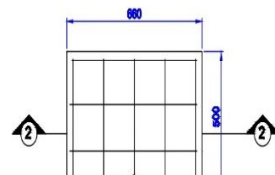

**100 @ 150 C/C
PRECAST RCC SLAB**

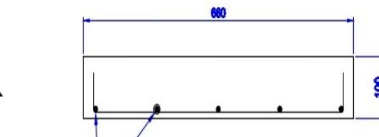

**100 @ 150 C/C
SECTION 2-2
SCALE 1:8**

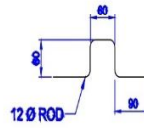

**12 Ø ROD
LIFTING HOOK
SCALE 1:8**

- NOTES:-**
 1. ALL DIMENSIONS ARE IN MM UNLESS NOTED OTHERWISE.
 2. FOLLOW WRITTEN DIMENSIONS ONLY. DO NOT SCALE THE DRAWING.

OWNER :
 CENTRAL UP GAS LIMITED

PROJECT :
 G/COPPER INSTALLATION WORKS

TITLE :
 TYPICAL BRICK WALL TRENCH
 (0.66 X 0.66 X 1.0)

SCALE: 1:8
 DWG: []
 DATE: []
 CAD A3

DRG. NO. C211036-10-03-34 REV-0

1 2 3 4 5 6 7 8

A

B

C

D

E

A

B

C

D

E

NOTES:-
 1. ALL DIMENSIONS ARE IN MM UNLESS NOTED OTHERWISE.
 2. FOLLOW WRITTEN DIMENSIONS ONLY. DO NOT SCALE THE DRAWING.

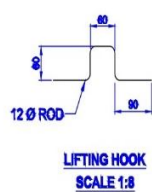
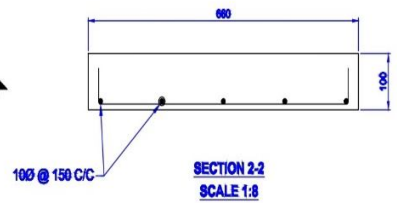
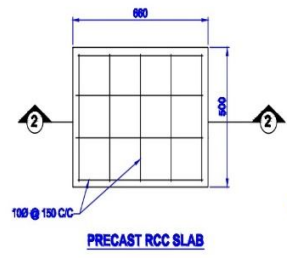
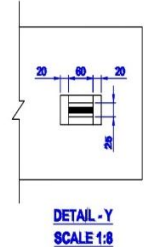
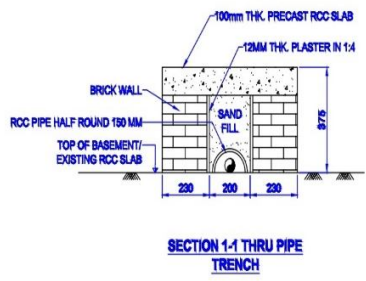
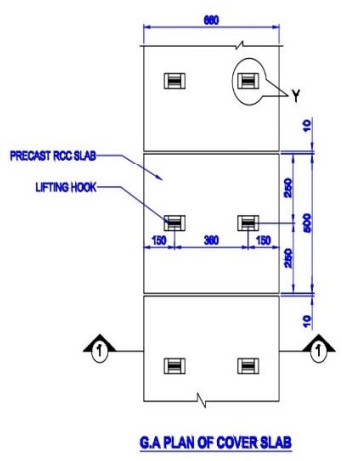

OWNER :			
CENTRAL UP GAS LIMITED			
PROJECT :			
GI/COPPER INSTALLATION WORKS			
TITLE :			
TYPICAL BRICK WALL TRENCH (0.375 X 0.66 X 1.0)			
SCALE	DATE	APPRE	DATE
1:10			
DRG. NO.	C211036-10-03-35 REV-0		
		CAD	A3

1 2 3 4 5 6 7 8

1 2 3 4 5 6 7 8

A

B

C

D

E

A

B

C

D

E

NOTES:-
 1. ALL DIMENSIONS ARE IN MM UNLESS NOTED OTHERWISE.
 2. FOLLOW WRITTEN DIMENSIONS ONLY. DO NOT SCALE THE DRAWING.

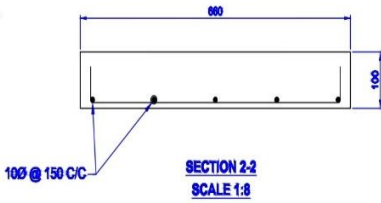
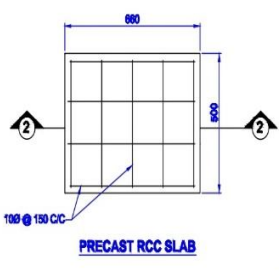
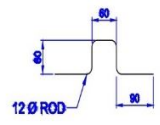
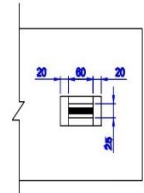
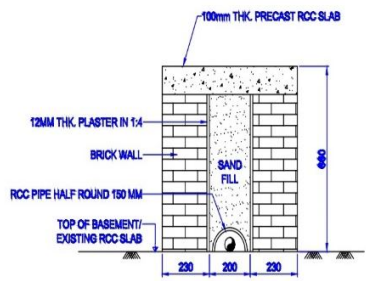
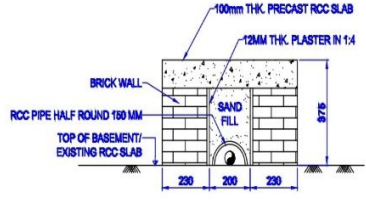
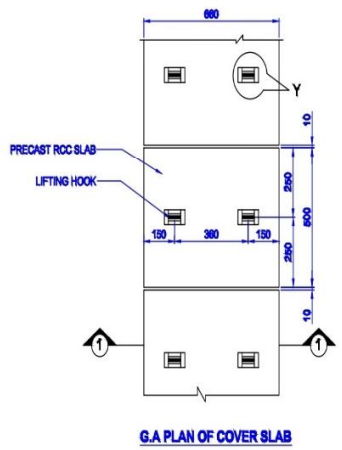

OWNER:		CENTRAL UP GAS LIMITED	
PROJECT:			
		GI/COPPER INSTALLATION WORKS	
TITLE:			
		TYPICAL BRICK WALL TRENCH UPTO 7M (ROAD CROSSING) INSIDE SOCIETY	
SCALE	DATE	APPRE	CAD A3
1:10			
DRG. NO.		C211036-10-03-43 REV-0	

1 2 3 4 5 6 7 8

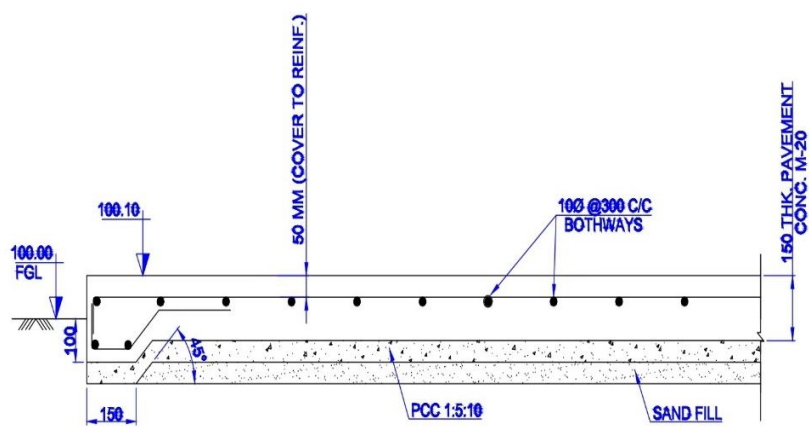

RCC PAVEMENT DETAIL

NOTES:-

1. ALL DIMENSIONS ARE IN MM UNLESS NOTED OTHERWISE.
2. FOLLOW WRITTEN DIMENSIONS ONLY. DO NOT SCALE THE DRAWING.

OWNER :		CENTRAL UP GAS LIMITED	
PROJECT :		GI/COPPER INSTALLATION WORKS	
TITLE :		STANDARD DETAIL OF RCC PAVEMENT	
SCALE	DATE	DATE	DATE
1:10			
DRG. NO.	C211036-10-03-17 REV-0		
		CAD	A3

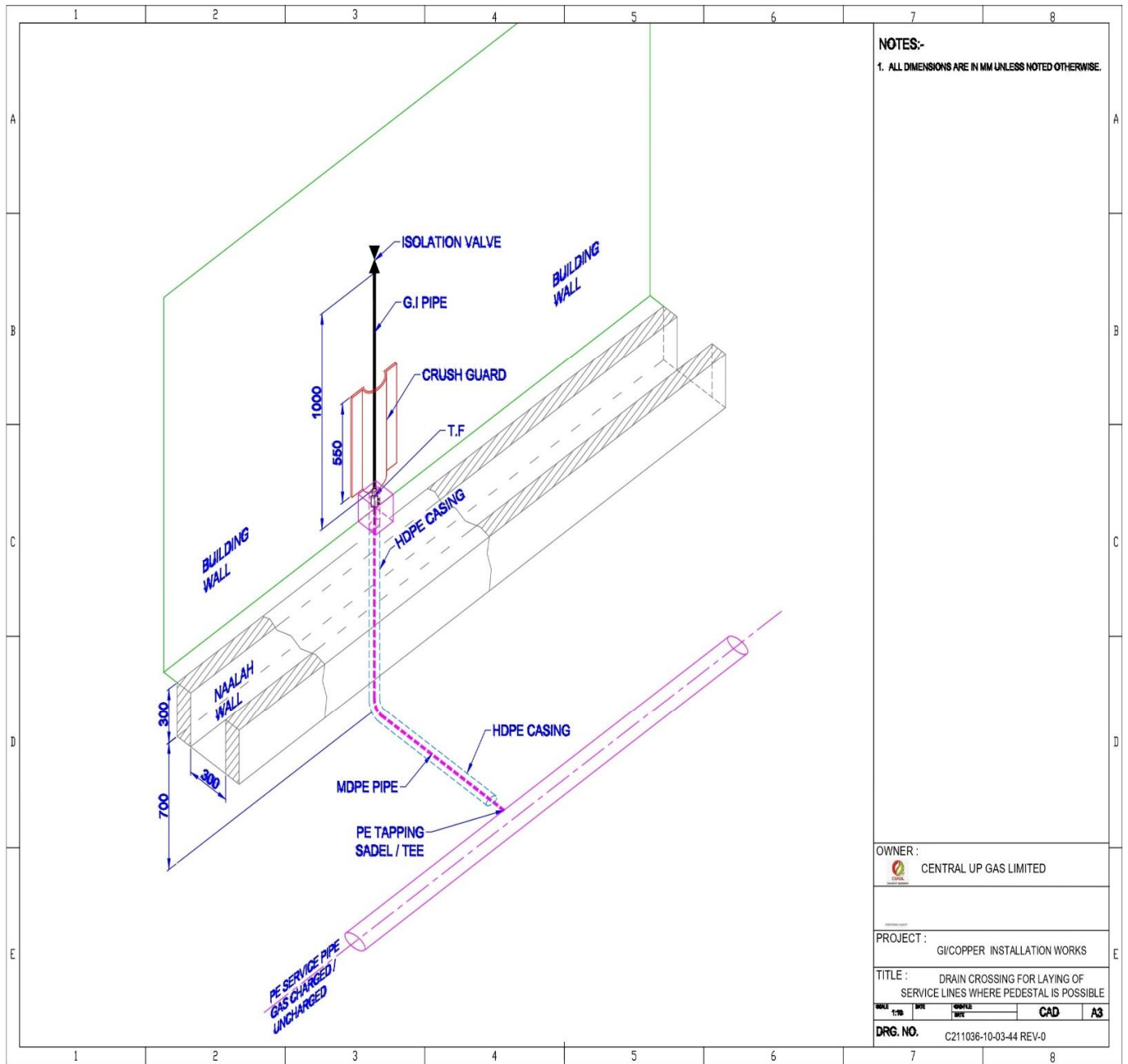

NOTES:-
 1. ALL DIMENSIONS ARE IN MM UNLESS NOTED OTHERWISE.

OWNER :		CENTRAL UP GAS LIMITED	
PROJECT :		GI/COPPER INSTALLATION WORKS	
TITLE :		DRAIN CROSSING FOR LAYING OF SERVICE LINES WHERE PEDESTAL IS POSSIBLE	
SCALE :	DATE :	FORMER :	CAD A3
DRG. NO. :		C211036-10-03-44 REV-0	

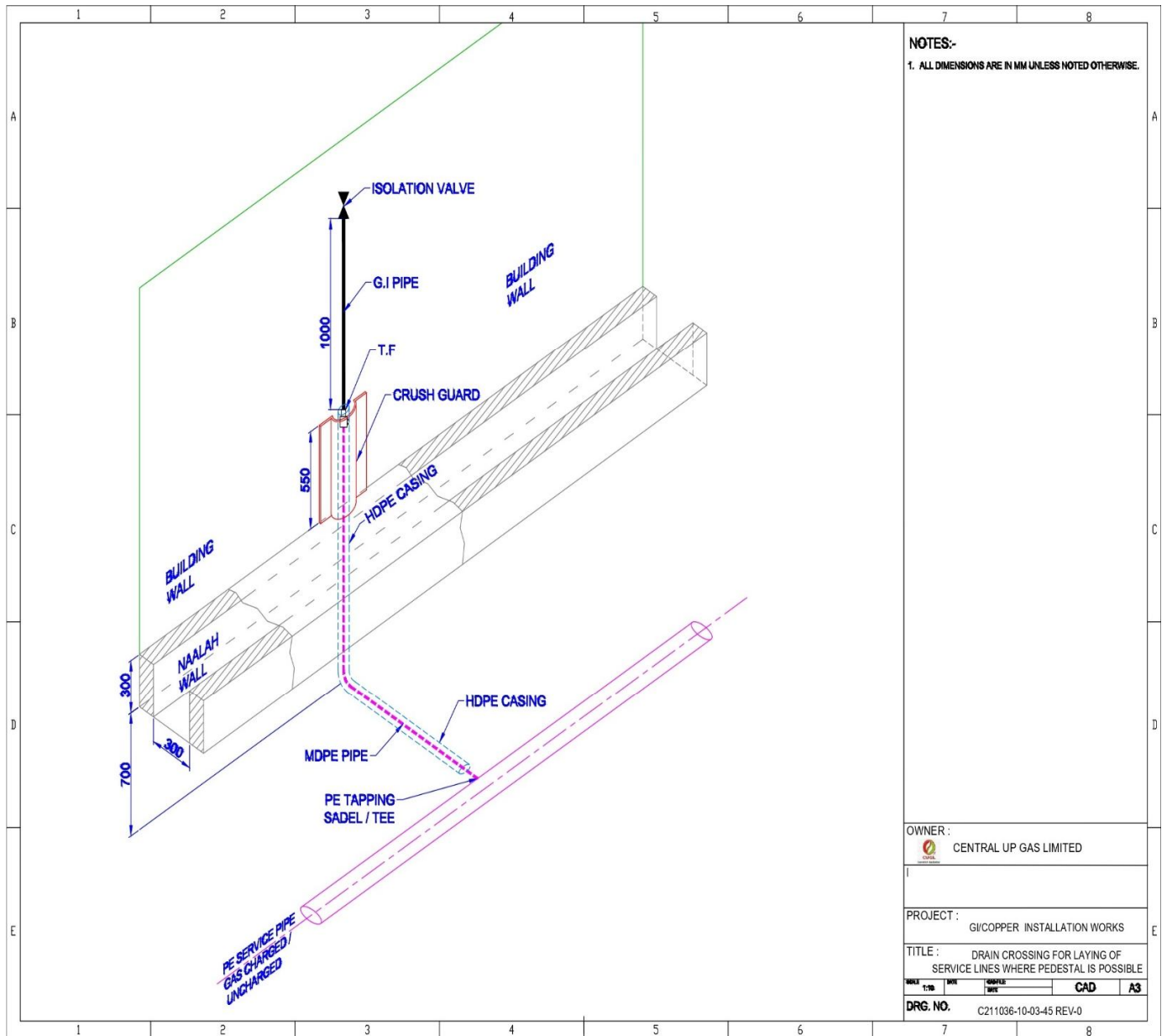

NOTES:-
 1. ALL DIMENSIONS ARE IN MM UNLESS NOTED OTHERWISE.

OWNER :		CENTRAL UP GAS LIMITED	
PROJECT :			
		GI/COPPER INSTALLATION WORKS	
TITLE :			
		DRAIN CROSSING FOR LAYING OF SERVICE LINES WHERE PEDESTAL IS POSSIBLE	
SCALE	DATE	DRAWN BY	CAD A3
DRG. NO.		C211036-10-03-45 REV-0	

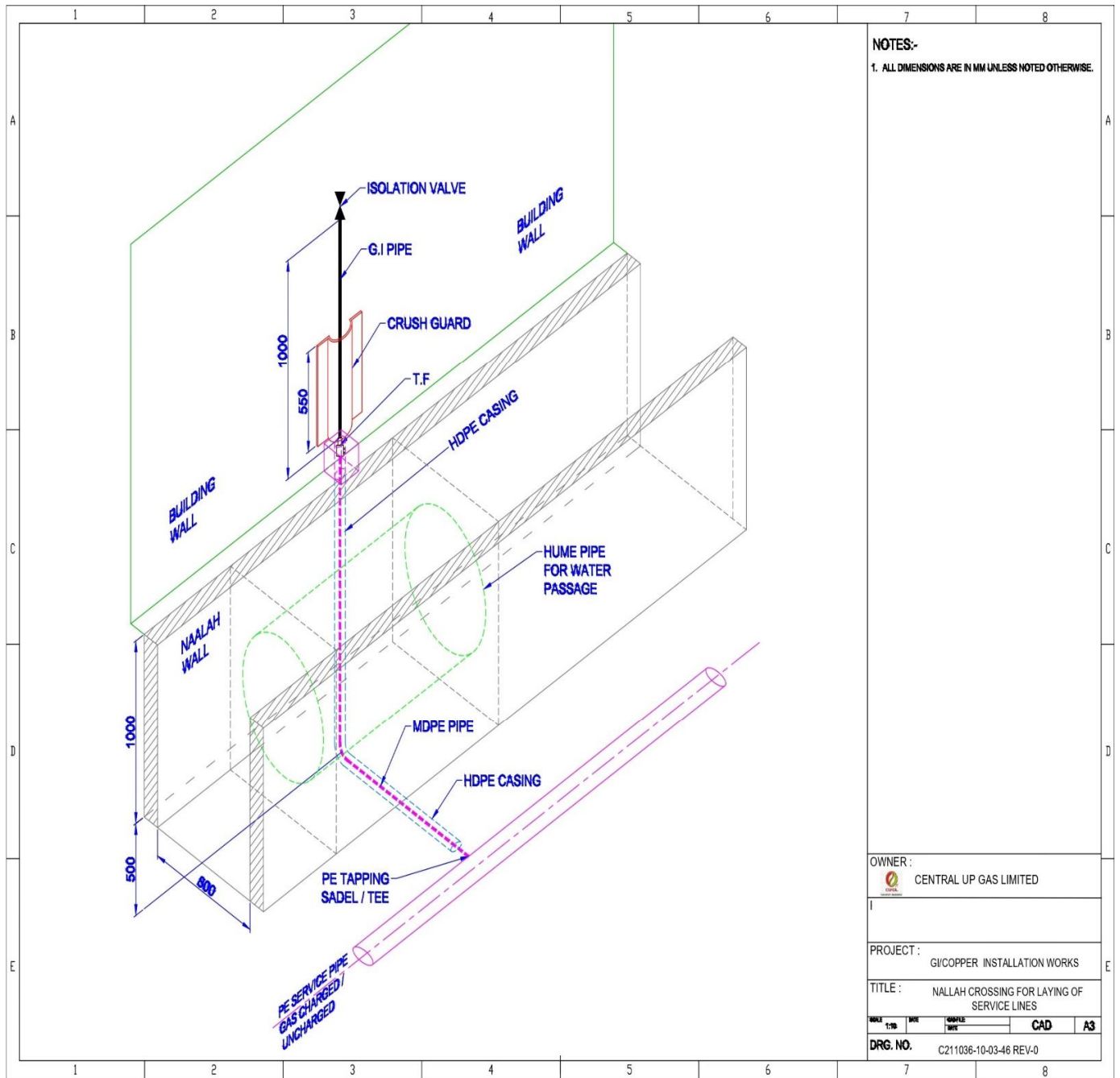

NOTES:-
 1. ALL DIMENSIONS ARE IN MM UNLESS NOTED OTHERWISE.

OWNER :		CENTRAL UP GAS LIMITED	
PROJECT :		GI/COPPER INSTALLATION WORKS	
TITLE :		NALLAH CROSSING FOR LAYING OF SERVICE LINES	
SCALE	DATE	APPRE	CAD
1:100			A3
DRG. NO.		C211036-10-03-46 REV-0	

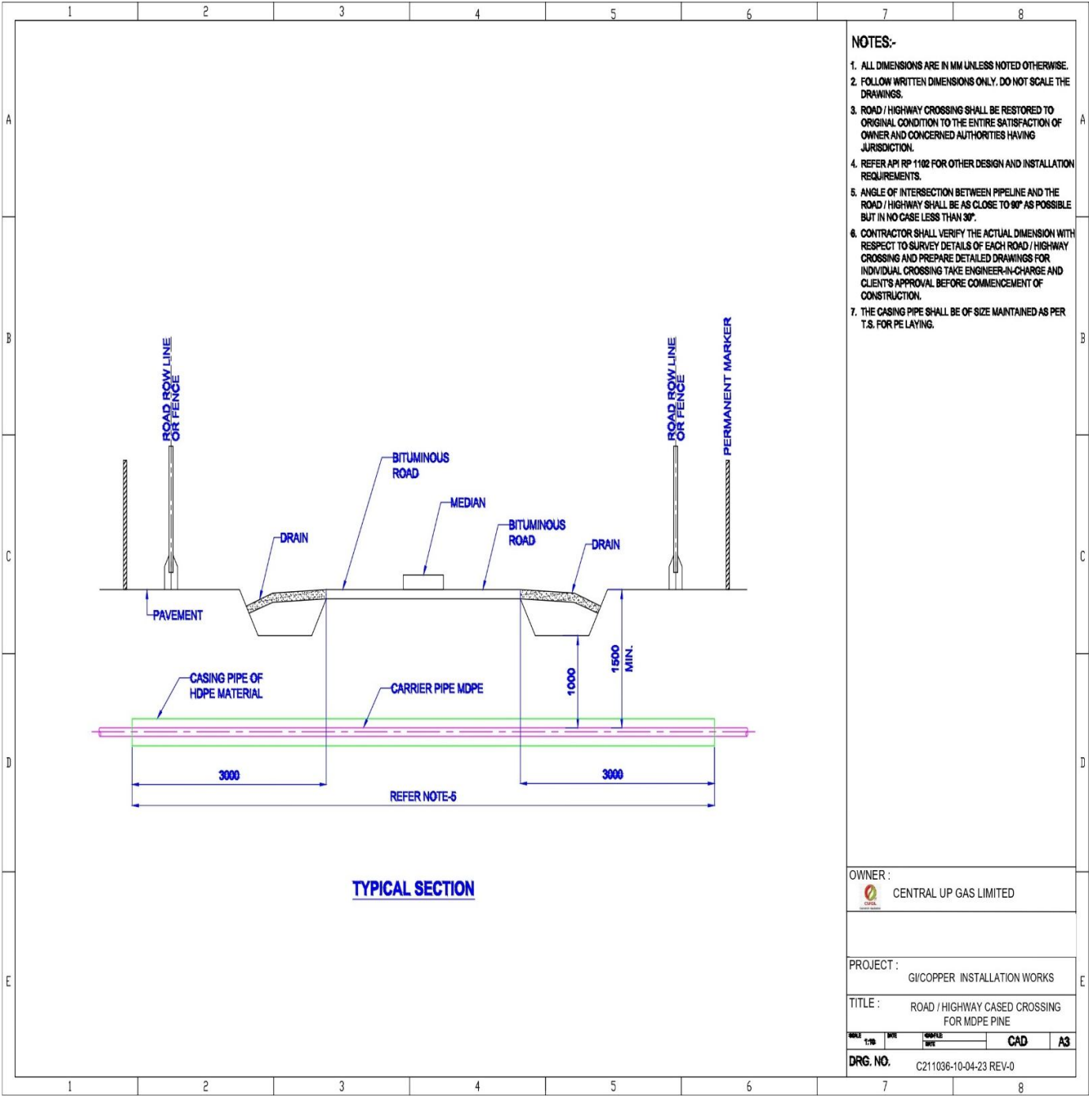

- NOTES:-**
1. ALL DIMENSIONS ARE IN MM UNLESS NOTED OTHERWISE.
 2. FOLLOW WRITTEN DIMENSIONS ONLY. DO NOT SCALE THE DRAWINGS.
 3. ROAD / HIGHWAY CROSSING SHALL BE RESTORED TO ORIGINAL CONDITION TO THE ENTIRE SATISFACTION OF OWNER AND CONCERNED AUTHORITIES HAVING JURISDICTION.
 4. REFER API RP 1102 FOR OTHER DESIGN AND INSTALLATION REQUIREMENTS.
 5. ANGLE OF INTERSECTION BETWEEN PIPELINE AND THE ROAD / HIGHWAY SHALL BE AS CLOSE TO 90° AS POSSIBLE BUT IN NO CASE LESS THAN 30°.
 6. CONTRACTOR SHALL VERIFY THE ACTUAL DIMENSION WITH RESPECT TO SURVEY DETAILS OF EACH ROAD / HIGHWAY CROSSING AND PREPARE DETAILED DRAWINGS FOR INDIVIDUAL CROSSING TAKE ENGINEER-IN-CHARGE AND CLIENT'S APPROVAL BEFORE COMMENCEMENT OF CONSTRUCTION.
 7. THE CASING PIPE SHALL BE OF SIZE MAINTAINED AS PER T.S. FOR PE LAYING.

TYPICAL SECTION

OWNER :		CENTRAL UP GAS LIMITED	
PROJECT :		GI/COPPER INSTALLATION WORKS	
TITLE :		ROAD / HIGHWAY CASED CROSSING FOR MDPE PIPE	
SCALE	DATE	DRW	APP
1:50			
DRG. NO.	C211036-10-04-23 REV-0		

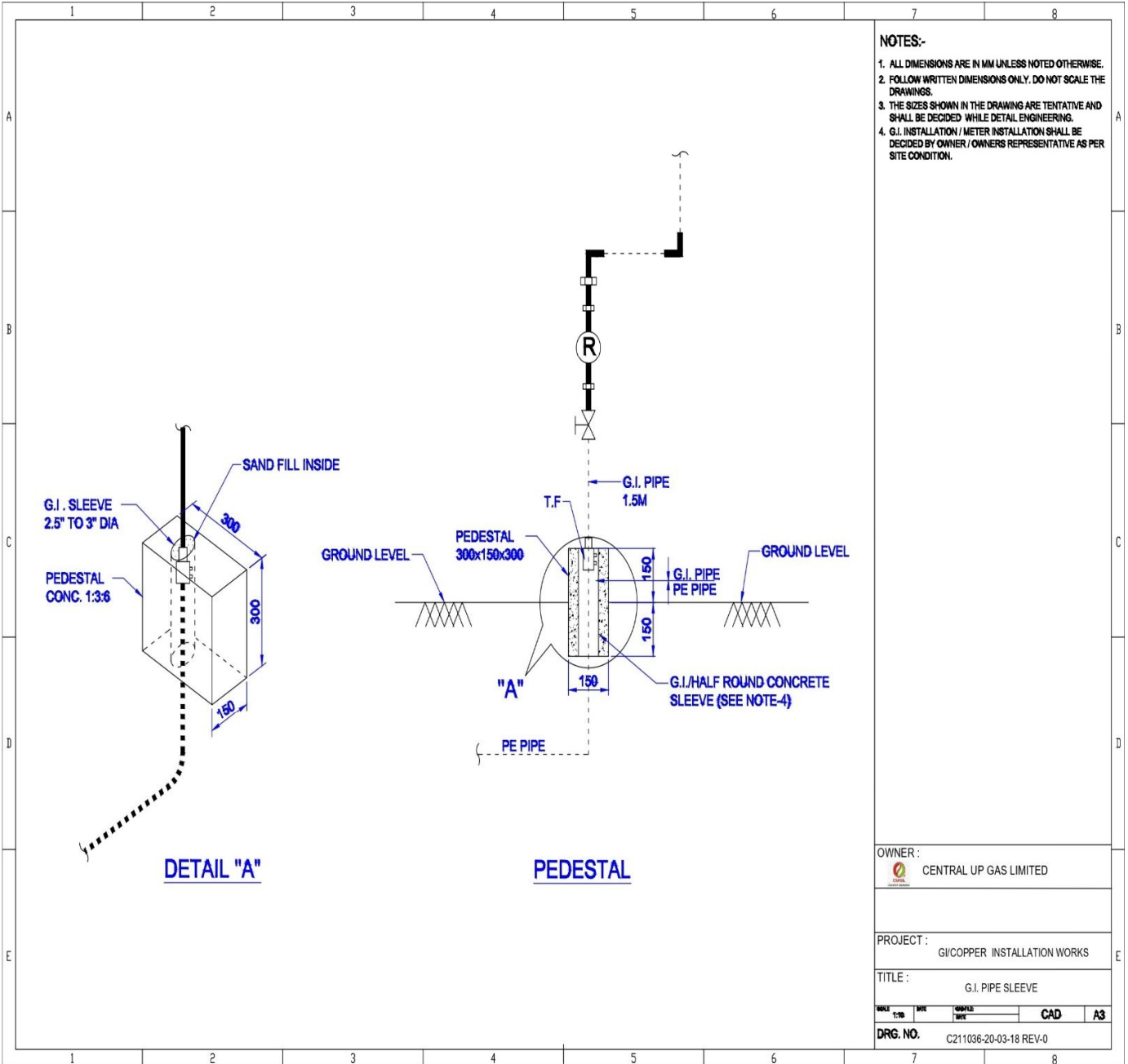

- NOTES:-**
1. ALL DIMENSIONS ARE IN MM UNLESS NOTED OTHERWISE.
 2. FOLLOW WRITTEN DIMENSIONS ONLY. DO NOT SCALE THE DRAWINGS.
 3. THE SIZES SHOWN IN THE DRAWING ARE TENTATIVE AND SHALL BE DECIDED WHILE DETAIL ENGINEERING.
 4. G.I. INSTALLATION / METER INSTALLATION SHALL BE DECIDED BY OWNER / OWNERS REPRESENTATIVE AS PER SITE CONDITION.

OWNER :		CENTRAL UP GAS LIMITED	
PROJECT :		GICOPPER INSTALLATION WORKS	
TITLE :		G.I. PIPE SLEEVE	
SCALE	DWG	DATE	CAD
1:10			A3
DRG. NO.		C211036-20-03-18 REV-0	

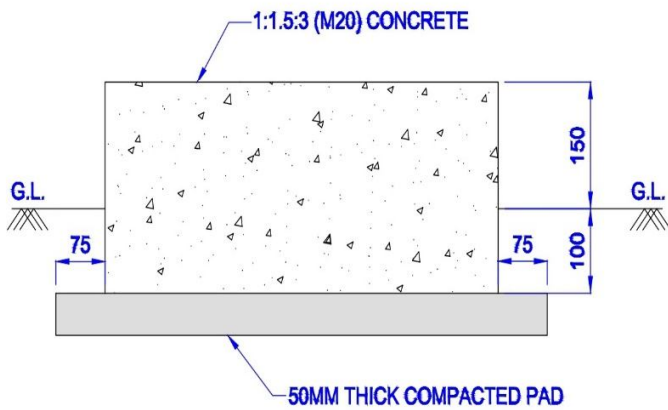
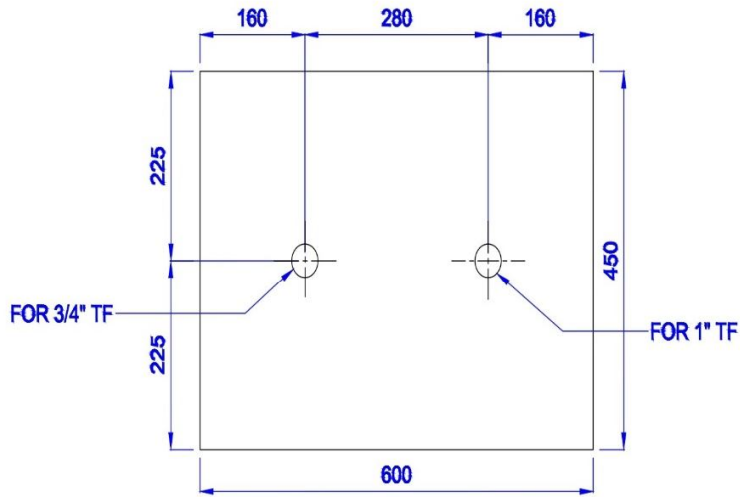

NOTES:-

1. ALL DIMENSIONS ARE IN MM UNLESS NOTED OTHERWISE.
2. FOLLOW WRITTEN DIMENSIONS ONLY. DO NOT SCALE THE DRAWING.

OWNER :
 CENTRAL UP GAS LIMITED

PROJECT :
 GI/COPPER INSTALLATION WORKS

TITLE :
 SCHEMATIC DIAGRAM OF FOUNDATION
 FOR SINGLE STREAM SERVICE REGULATOR

SCALE	DATE	DRAWN BY	CAD	A3
-------	------	----------	-----	----

DRG. NO. C211036-20-03-39 REV-0

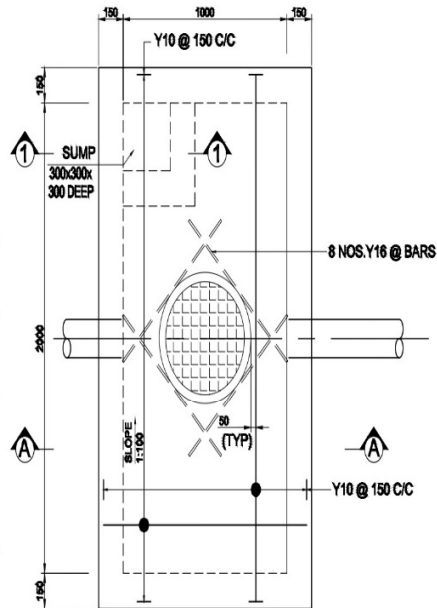

VALVE PIT PLAN
(SCALE 1:20)

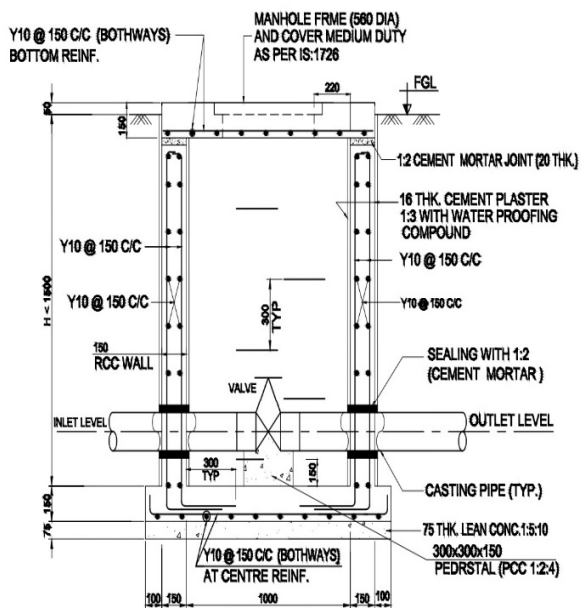

SECTION A-A
(SCALE 1:20)

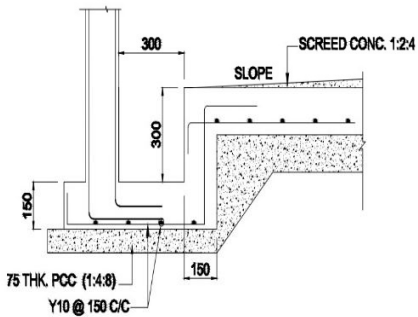

SECTION 1-1
(SCALE 1:10)

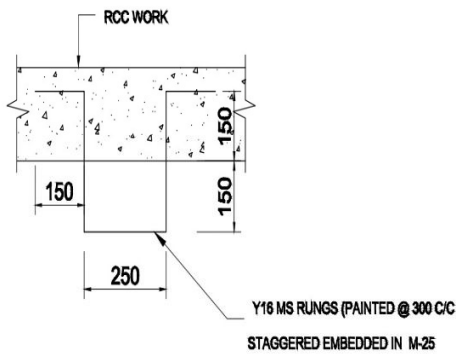

TYPICAL DETAILS OF MS RUNGS
(SCALE 1:10)

NOTES:-

1. ALL DIMENSIONS ARE IN MM UNLESS NOTED OTHERWISE.
2. FOLLOW WRITTEN DIMENSIONS ONLY. DO NOT SCALE THE DRAWING.
3. CLEAR COVER TO MAIN REINFORCEMENT SHALL BE @ 25 AS 20mm
4. GRADE OF CONCRETE USED SHALL BE M-25 CONFORMING.
5. REINFORCEMENT SHALL BE IN 150 BARS OF (GRADE Fe 415) CONFORMING TO IS:1786.

OWNER:	CENTRAL UP GAS LIMITED		
PROJECT:	GI/COPPER INSTALLATION WORKS		
TITLE:	STANDARD DETAIL OF RCC VALVE CHAMBER (TYPE-1)		
SCALE:	DATE:	BY:	CAD
AS SHOWN	01-07-2014	JPR	A3
DRG. No:1007 -20-03-20 REV-0			

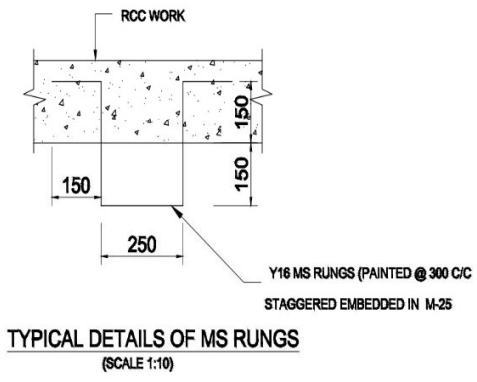
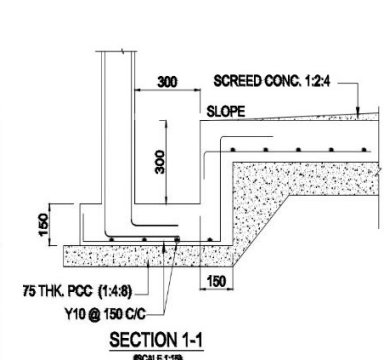
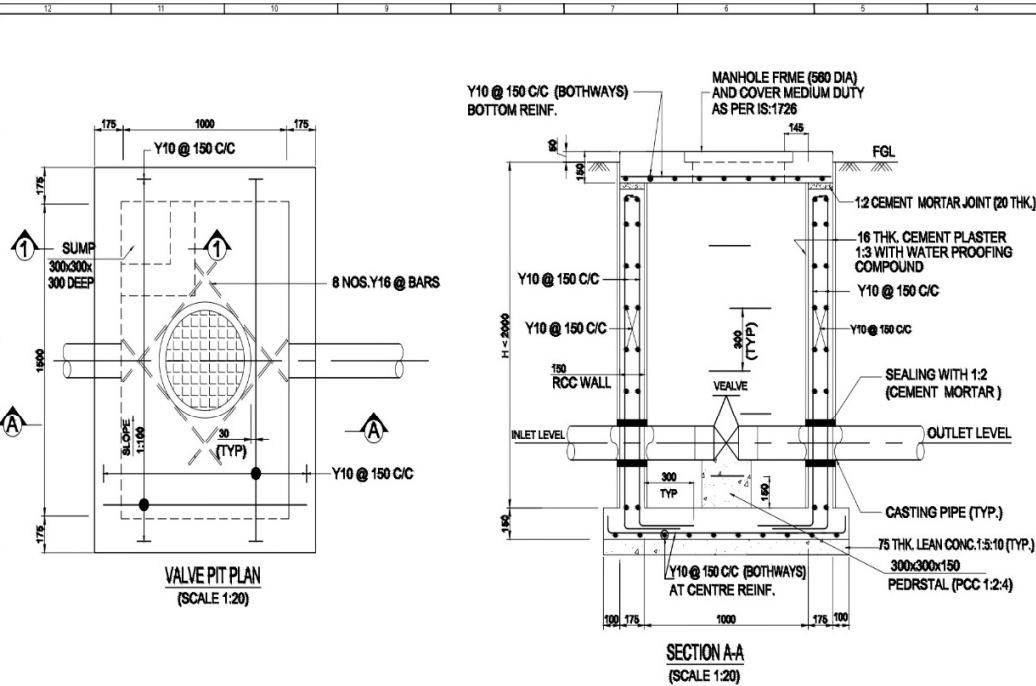

- NOTES:-**
1. ALL DIMENSIONS ARE IN MM UNLESS NOTED OTHERWISE.
 2. FOLLOW WRITTEN DIMENSIONS ONLY. DO NOT SCALE THE DRAWING.
 3. CLEAR COVER TO MAIN REINFORCEMENT SHALL BE @ 25/30/40mm.
 4. GRADE OF CONCRETE USED SHALL BE M-25 CONFORMING.
 5. REINFORCEMENT SHALL BE IN 40 BARS OF (GRADE Fe 415) CONFORMING TO IS:1786.

OWNER:		CENTRAL UP GAS LIMITED	
PROJECT:		GI/COPPER INSTALLATION WORKS	
TITLE:		STANDARD DETAIL OF RCC VALVE CHAMBER (TYPE-2)	
DATE AS SHOWN	DATE	SCALE	NO.
01.07.14	01.07.14	CAD	A3
DRG. No. 1007-20-03-21 REV-0			

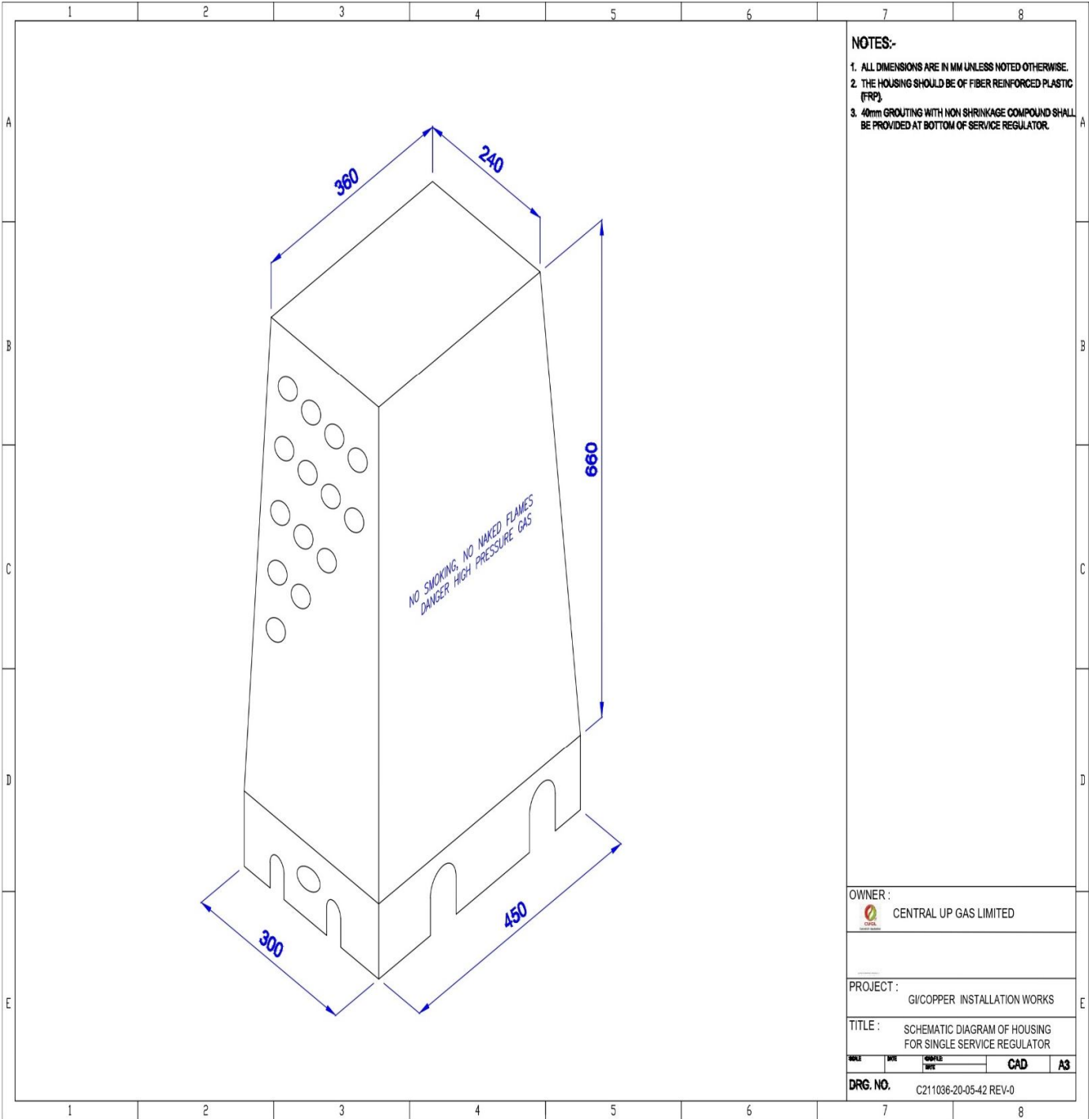

NOTES:-

1. ALL DIMENSIONS ARE IN MM UNLESS NOTED OTHERWISE.
2. THE HOUSING SHOULD BE OF FIBER REINFORCED PLASTIC (FRP).
3. 40mm GROUTING WITH NON SHRINKAGE COMPOUND SHALL BE PROVIDED AT BOTTOM OF SERVICE REGULATOR.

OWNER :		CENTRAL UP GAS LIMITED	
PROJECT :		GI/COPPER INSTALLATION WORKS	
TITLE :		SCHEMATIC DIAGRAM OF HOUSING FOR SINGLE SERVICE REGULATOR	
SCALE	DATE	DRAWN BY	CAD A3
DRG. NO.	C211036-20-05-42 REV-0		

NOTES:-

1. ALL DIMENSIONS ARE IN MM UNLESS NOTED OTHERWISE.
2. FOLLOW WRITTEN DIMENSIONS ONLY. DO NOT SCALE THE DRAWING.
3. CLEAR COVER TO MAIN REINFORCEMENT SHALL BE @ 25/30mm
4. GRADE OF CONCRETE USED SHALL BE M-25 CONFORMING.
5. REINFORCEMENT SHALL BE 10MM BARS OF GRADE Fe 415 CONFORMING TO IS:1786.

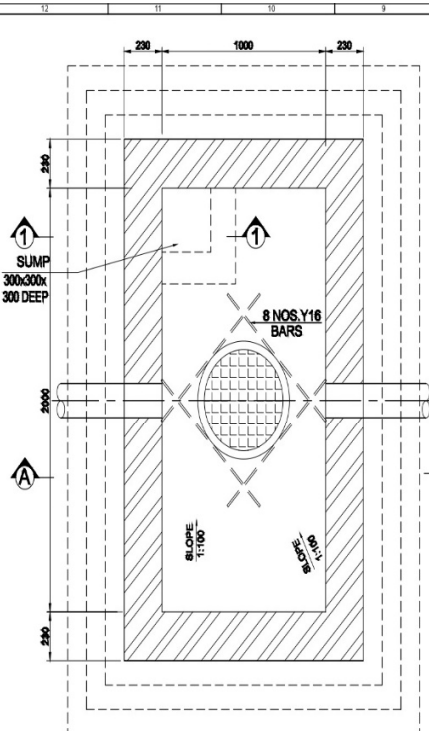

VALVE PIT PLAN
(SCALE 1:20)

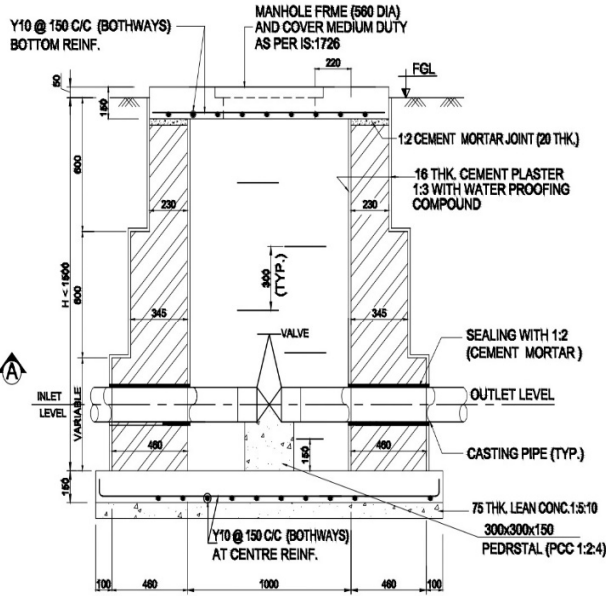

SECTION A-A
(SCALE 1:20)

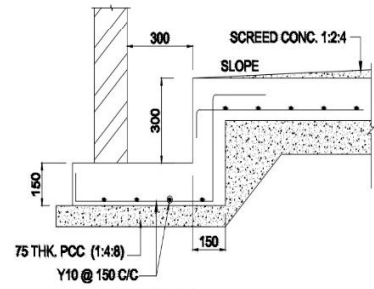

SECTION 1-1
(SCALE 1:10)

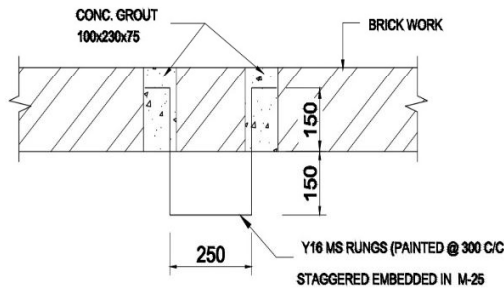

TYPICAL DETAILS OF MS RUNGS
(SCALE 1:10)

OWNER:		CENTRAL UP GAS LIMITED	
PROJECT:		GI/COPPER INSTALLATION WORKS	
TITLE:		STANDARD DETAIL OF BRICK VALVE CHAMBER (TYPE-1)	
DATE AS SHOWN	DATE	CAD	A3
01-07-2014			
DRG. No. 1007 -20-03-21 REV-0			

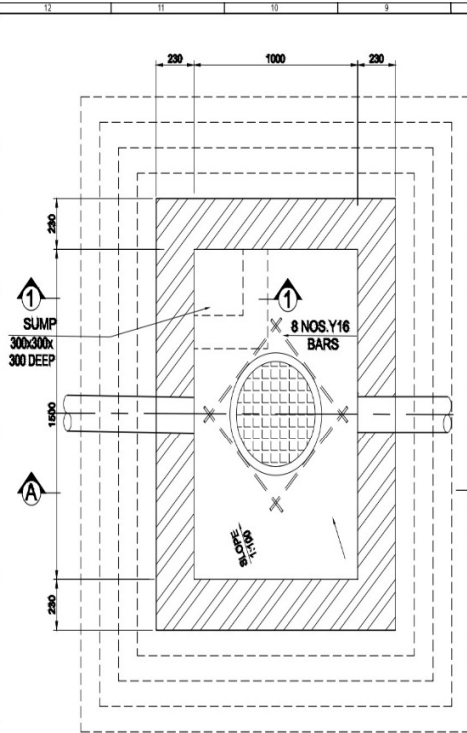

VALVE PIT PLAN
(SCALE 1:20)

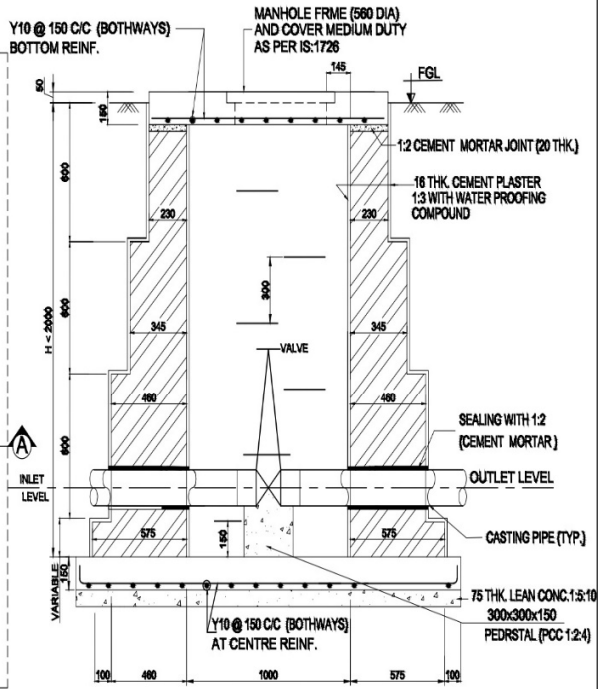

SECTION A-A
(SCALE 1:20)

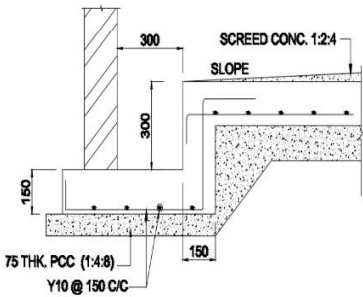

SECTION 1-1
(SCALE 1:10)

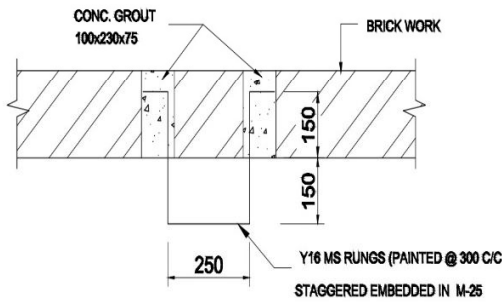

TYPICAL DETAILS OF MS RUNGS
(SCALE 1:10)

NOTES:-

1. ALL DIMENSIONS ARE IN MM UNLESS NOTED OTHERWISE.
2. FOLLOW WRITTEN DIMENSIONS ONLY, DO NOT SCALE THE DRAWING.
3. CLEAR COVER TO MAIN REINFORCEMENT SHALL BE @ 25 TO 30MM.
4. GRADE OF CONCRETE USED SHALL BE M-25 CONFORMING.
5. REINFORCEMENT SHALL BE HYSD BARS OF GRADE Fe-415 CONFORMING TO IS:1786.

OWNER:  CENTRAL UP GAS LIMITED

PROJECT: GI/COPPER INSTALLATION WORKS

TITLE: **STANDARD DETAIL OF BRICK VALVE CHAMBER (TYPE-2)**

ISSUE NO.	DATE	DESCRIPTION	BY	CHKD BY
AS SHOWN	01-07-2014			

DRG. No. 1007-20-03-21 REV-0

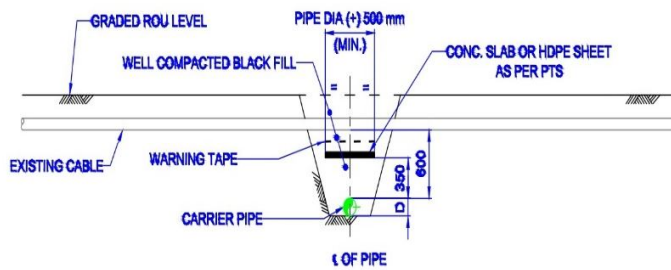
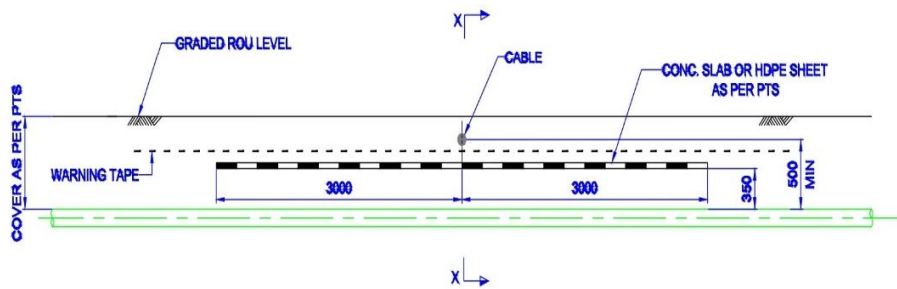

SECTION X-X

NOTES:-

1. ALL DIMENSIONS ARE IN MM UNLESS NOTED OTHERWISE.
2. FOLLOW WRITTEN DIMENSIONS ONLY. DO NOT SCALE THE DRAWINGS.
3. A MODIFIED PIPELINE WARNING SIGN SHALL BE INSTALLED CLOSE TO THE CROSSING.
4. IN CASE OF ARMoured OFC CABLE, C.P. BONDING IS TO BE PROVIDED BETWEEN PIPELINE AND CABLE ARMOUR. IN CASE OF UNARMoured CABLE, ARRANGEMENT FOR SHIELDING (BY PROVIDING CASING ON EITHER SIDE OF THE PIPELINE OR CABLE) SHALL BE CONSIDERED.
5. APPROVAL OF THE CROSSING SHALL BE OBTAINED FROM CONCERNED AUTHORITIES.

OWNER :
 CENTRAL UP GAS LIMITED

PROJECT :
 G/COPPER INSTALLATION WORKS

TITLE :
 TYPICAL UNDERGROUND CABLE CROSSING DETAILS

SCALE	DATE	APP'D	DATE	CAD	AS
1:75					

DRG. NO. C211036-10-03-24 REV-0

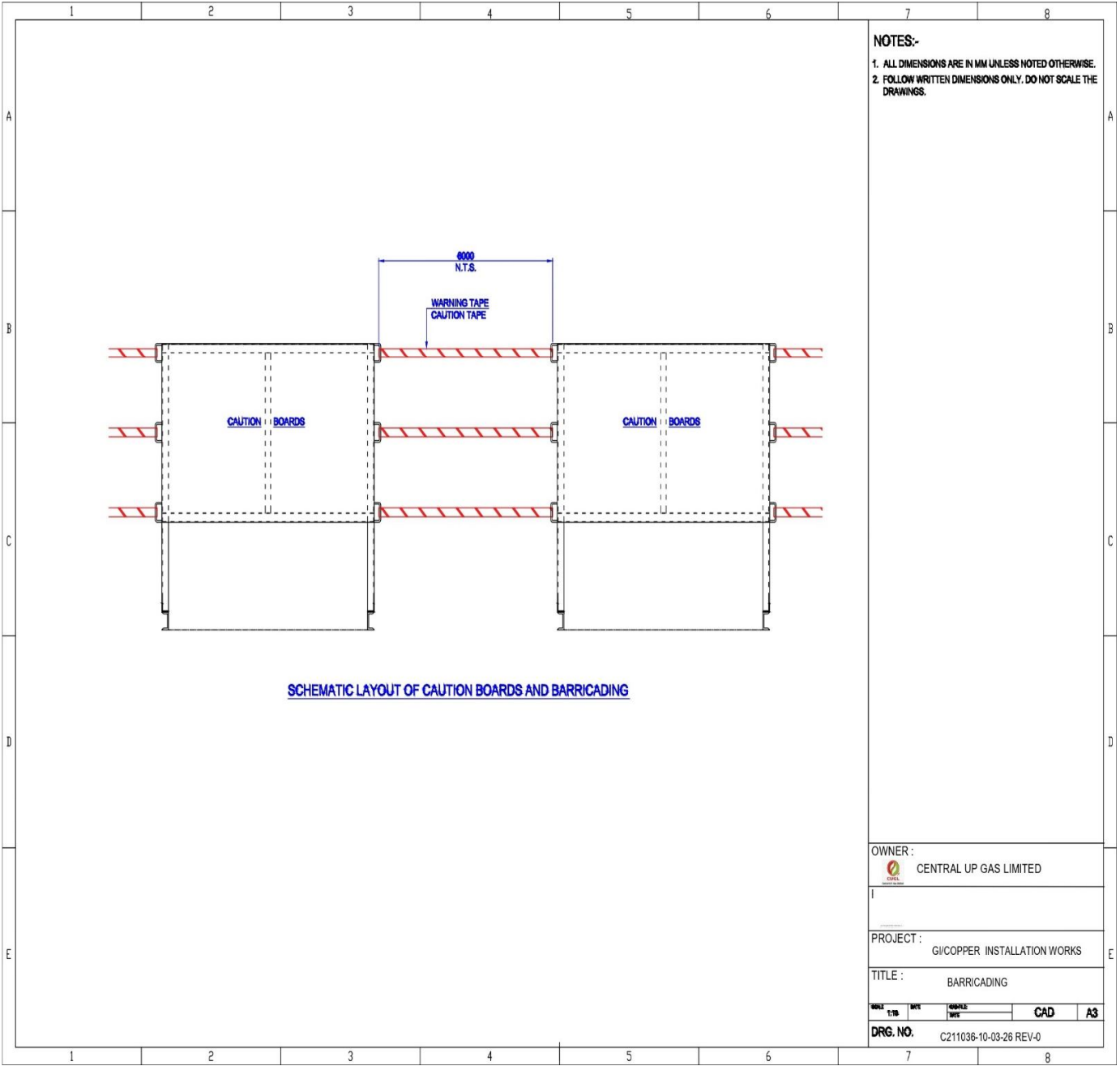

NOTES:-
 1. ALL DIMENSIONS ARE IN MM UNLESS NOTED OTHERWISE.
 2. FOLLOW WRITTEN DIMENSIONS ONLY. DO NOT SCALE THE DRAWINGS.

OWNER :		CENTRAL UP GAS LIMITED	
PROJECT :			
		GI/COPPER INSTALLATION WORKS	
TITLE :			
		BARRICADING	
SCALE	DATE	DESIGNED BY	CAD
1:10			A3
DRG. NO.		C211036-10-03-26 REV-0	

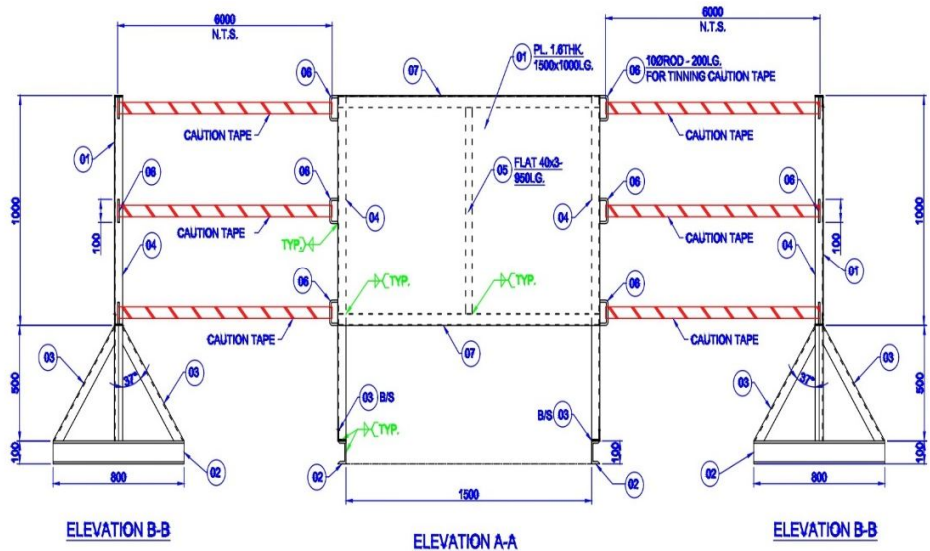

IN RED → **CAUTION** ← CLIENT LOGO

WORK IN PROGRESS

LAYING OF NATURAL GAS PIPELINE
 CLIENT : OWNER'S NAME
 CONTRACTOR NAME:
 DATE OF COMMENCEMENT:
 DATE OF COMPLETION:
 EMERGENCY PHONE NOS:

IN BLACK

TO BE PRINTED ON ITEM NO. 01

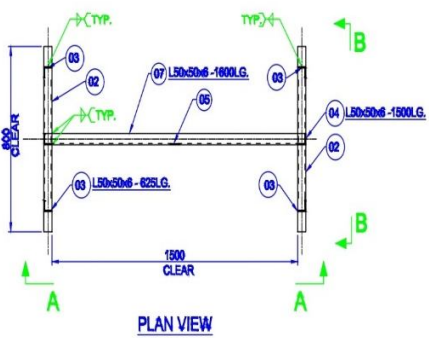

NOTES:-

1. ALL DIMENSIONS ARE IN MM UNLESS NOTED OTHERWISE.
2. FOLLOW WRITTEN DIMENSIONS ONLY. DO NOT SCALE THE DRAWINGS.

BILL OF MATERIAL						
Item	Section	Width	Length	Item Qty.	Weight	Total Weight
				(As Marked)	(As Marked)	In Kgs.
1.	PL-1.6 THK.	1600	1000	1	12.56	20.10
2.	ISMC 100	-	800	2	9.20	14.72
3.	L50x50x6	-	825	4	4.50	11.25
4.	L50x50x6	-	1500	2	4.50	13.50
5.	Flat 3THK.	900	40	1	0.94	0.63
6.	100 Rod	-	200	6	0.62	0.74
7.	L50x50x6	-	1600	2	4.50	14.40
Grand Total (Kgs)						74.74

OWNER:
 CENTRAL UP GAS LIMITED

PROJECT:
 GI/COPPER INSTALLATION WORKS

TITLE:
 CAUTION BOARD & TAPE ARRANGEMENT
 IN G.I./RISER INSTALLATION

SCALE: 1:100 DATE: 03/26/2015 SHEET NO: CAD A3

DRG. NO. C211036-10-03-26 REV-0



SECTION - B-B

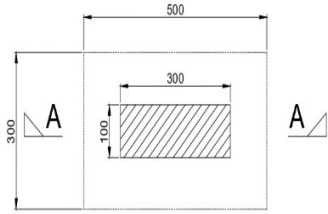

PLAN

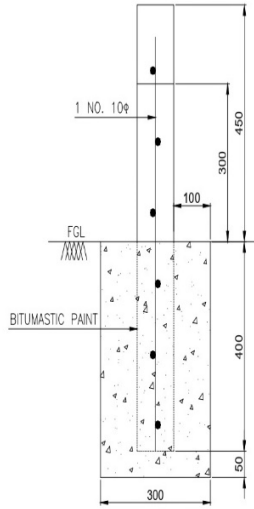

SECTION - C-C

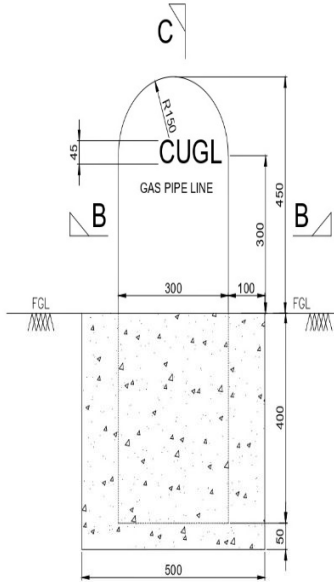

**SECTION - A-A
(FOR DIMENSION)**

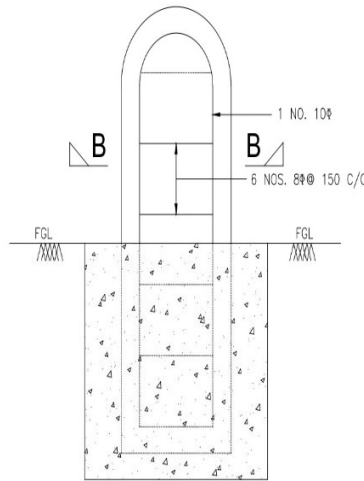

**SECTION - A-A
(FOR REINFORCEMENT)**

NOTES:

1. ALL DIMENSIONS ARE IN MM UNLESS OTHERWISE SPECIFIED.
2. FOLLOW WRITTEN DIMENSIONS ONLY. DO NOT SCALE THE DRAWING.
3. CLEAR COVER TO MAIN REINFORCEMENT SHALL BE (a) SLAB 20mm.
4. GRADE OF CONCRETE USED SHALL BE M-25 CONFORMING.
5. REINFORCEMENT SHALL BE HYSD BARS OF (GRADE Fe 415) CONFORMING TO IS:1786.

REV	DATE	DESCRIPTION	PREP.	CHKD.	APPD.
0		ISSUED FOR CONSTRUCTION	AK	NA	HK

CLIENT: CENTRAL UP GAS LIMITED

PROJECT: CITY GAS DISTRIBUTION PROJECT

SCALE: TITLE
NTS: RCC ROUTE MARKER

SIZE	CLIENT JOB NO.	DRAWING NUMBER	SHEET	REV.
A3	1036		1 OF 1	0